

# Table of Contents

- Introduction ..... 3
- Supervisor Setup ..... 9
  - Soft Key: PRINT SETUP ..... 10
  - Soft Key: SAMPLE SETUP ..... 18
  - Soft Key: ACCURCY SETUP ..... 20
  - Soft Key: PORTS SETUP ..... 22
  - Soft Key: TIME/DATE ..... 24
  - Soft Key: UNITS ENABLED ..... 28
  - Soft Key: DATABASE SETUP ..... 32
  - Soft Key: TRANSAC SETUP ..... 36
  - Soft Key: ID NAME SETUP ..... 40
  - Soft Key: MACRO SETUP ..... 44
  - Soft Key: SETUP SECURTY ..... 54
  - Soft Key: BEEPER CONTROL ..... 56
- Bases Setup ..... 59
  - Soft Key: CALIB ..... 60
  - Soft Key: SPEED ..... 64
  - Soft Key: ZERO ..... 66
  - Soft Key: RESOLUT ..... 68
  - Soft Key: INFO ..... 70
  - Soft Key: NAME ..... 72
  - Soft Key: ADDRESS ..... 74
  - Soft Key: BASERST ..... 78
- Technical Setup ..... 81
  - Soft Key: GREETNG ..... 82
  - Soft Key: BACKLIT ..... 84
  - Soft Key: SETUP TRANSFR ..... 88
  - Soft Key: RESET ..... 92

Soft Key: AUTO SWITCH .....	96
Soft Key: ALARMS .....	98
Soft Key: DIG INP .....	102
Soft Key: SETUP SECURTY .....	104
Soft Key: HYSTERS .....	106
Soft Key: APW QTY .....	108
Appendix A: RS232 Serial Port Communications .....	111
Appendix B: Scriptcoder™ Custom Label Printing .....	119
Appendix C: Setra Dialog Language .....	127
Appendix D: Battery Option .....	130
Appendix E: Strain Gauge Remote Scale Option .....	132
Appendix F: Relay Box .....	138
Appendix G: Glossary .....	142
Appendix H: Specifications .....	144
Appendix I: Warranty .....	147
Appendix J: Warnings .....	148
FCC Warning .....	149
EC Declaration of Conformity .....	150
Index .....	151

# Introduction



# Introduction

For many counting or weighing applications, the Super II default settings are adequate and the scale can be used just as it comes from the factory. However, often the scale performance can be enhanced or operation simplified if the factory settings are changed, or if some of the more specialized features are enabled. This manual is designed to instruct the programmer in the procedures used to change factory default settings for numerous scale features and, also, to describe how to use certain other features that are not enabled at the factory. Access to these settings can be password protected to assure that the settings, once programmed, are only changed by authorized personnel.

The manual is divided into four sections: Supervisor Setup, Technical Setup, Bases Setup and the appendices. Supervisor Setup, in general, allows application specific customization of the scale, such as programming the minimum sample size that will be allowed for counting certain parts, setting the baud rate for communicating with a particular printer, changing the name of field identifiers that will appear on printed labels and customizing prompts that will walk the user through a recurring counting or weighing transaction. Technical Setup allows customization of the scale that tends to be more related to scale performance, as well as several other scale specific parameters. The Bases Setup section describes how to configure the network of bases, including performance parameters. The fourth section consists of appendices that explain, at length, how to use two standard features, RS232 data communications and the ScriptCoder label making routine. It also describes the use of the optional battery and strain gauge remote scale option which can be purchased separately.

This setups manual will enable customization and/or implementation of the following scale features:

## Printing

Text and bar coded labels can be printed directly from the Super II controller using the optional Dymo® SETRA 300 printer or the more advanced Eltron thermal printer (not available from Setra). ScriptCoder allows easy interfacing to a wide variety of other printers and use of its powerful scripting language can produce fairly complex labels, if needed.

## Multiple Scale Systems

As described in the Bases Setup section of this manual, a single Super II scale can be converted into a system consisting of one Super II controller connected to and operating up to eight separate bases. These bases can be either Setra variable capacitance load cell bases or more conventional strain gauge load cell bases, or a combination of both. This feature provides the advantage of integrating, at one workstation, high resolution, low capacity bases for the optimal development of average piece weights, with low resolution, high capacity bases for counting and weighing very large, bulky loads.

## Internal Database

A flexible internal database can be used to store part numbers and associated data for up to 750 inventory items. The ability to instantly recall an item's average piece weight from the database can eliminate repetitive sampling when that part is frequently counted. The ability to recall descriptive information from the database reduces the need to input data when transaction receipts or other labels are generated.

## Transaction Log

Resident in the scale's database, this feature chronologically stores the results of each weighing or counting operation. The part number, the operator's name, the time and date of the transaction and the quantity counted can be automatically stored when the appropriate key is pressed. Transaction reports can be periodically printed to help track material flow and reconcile inventory miscounts.

## Prompting Macros

The scale's display can prompt a user through a series of steps for repetitive tasks. The macros are easily written using this manual and the Super II controller. They can consist of up to 100 individual steps and can be written in some foreign languages or industry jargon, if desired. The macros help to simplify scale operation for novice or untrained operators by providing one-button operation.

## Programmable Accuracy and Sample Size

This feature permits the programmer to make a trade-off between the sample size that is hand counted onto the scale and the accuracy that the scale can potentially deliver. The higher the accuracy setting selected, the larger the sample weight required. If the parts are small, a high accuracy setting can mean that the scale will prompt an operator to hand count very large samples onto the scale. Hand counting large samples can, in itself, introduce operator errors as well as slow down the scale counting process. Hand counting very small samples (fewer than 5 pieces) may produce errors, since the average piece weight may not be representative of the entire population of parts. The programmer uses these settings to minimize errors introduced by nonuniform parts, hand counting or insufficient sample weight.

## Programmable Units of Measure

A preprogrammed list of weighing units is available in the User Menu. This feature allows the programmer to make several units available to the user, or only one unit if one is less likely to create confusion. Customized weighing units for special applications can be programmed and can be easily accessed by the user when needed.

## Setra Dialog Language (SDL) (New in Software Ver 3.01)

Setups, database records and transaction logs can be saved and restored using the Setra dialogue language.

A brief synopsis of the programming functions as they appear in the menu selections are listed below:

### Supervisor Menu:

PRINT SETUP	Program the interval print time period as well as the print formats for the 10 print registers.
SAMPLE SETUP	Program the minimum sample size, the sample size selections and to include a sample size selection menu as part of your default operation.
ACCURCY SETUP	Program the minimum scale performance accuracy based on the sample weight.
PORTS SETUP	Program the baud rate and parity characteristics of the three serial ports.
TIME DATE	Program the time and date and their reporting formats on power-up and when printing.
UNITS ENABLED	Select the availability of the various weighing units of measure as well as program the user definable unit of measure.
DATABASE SETUP	Select the Database fields for display, print the databases, and set the database record protection.

TRANSAC SETUP	Activate and choose the fields to record in the transaction log, print the transaction log or transfer to a computer, and clear the transaction log.
ID NAME SETUP	Change the names of the ID fields.
MACRO SETUP	Program up to ten macros (a series of scale operation steps) along with customizable prompts.
SETUP SECURTY	Program password protection for the Supervisor menus
BEEPER CONTROL	Allows the beeper to be disabled.

#### **Bases Menu:**

CALIB	Perform a Span calibration and access the factory linearity calibration and test menu.
UPDATE SPEED	Select the filtering and update rate.
ZERO TRACK	Set the level of Zero Tracking.
RESOLUT	Set the displayed weight resolution of the scale.
INFO	Display information about the bases such as display resolution, zero tracking, sample resolution, and software revision.
NAME	Change the name of a base.
ADDRESS	Display and change the network address of the bases.
BASERST	Force the controller to evaluate the base network.

#### **Technical Menu:**

GREETNG	Change the greeting message on power-up.
BACKLIT	Set up the battery saving modes for the backlight option (if available).
SETUP TRANSFR	Send setup and database information through the ports. (Note: Available in Software Version 3.01 and greater.)
RESET	Return to the factory defaults and clear out separately the Database, Print Registers, and Macros.
AUTO SWITCH	Program automatic switching options among multiple bases.

ALARMS	Configure and enable/disable the digital output alarms.
DIG INP	Set up the controller for control by outside equipment.
SETUP SECURTY	Program password protection for the Technical and Bases Menu.
HYSTERS	Set up display hysteresis for more stable display.
APW QTY	Program the number of pieces by which the scale counts



# Supervisor Setup

# Supervisor Setup Menu: Soft Key PRINT

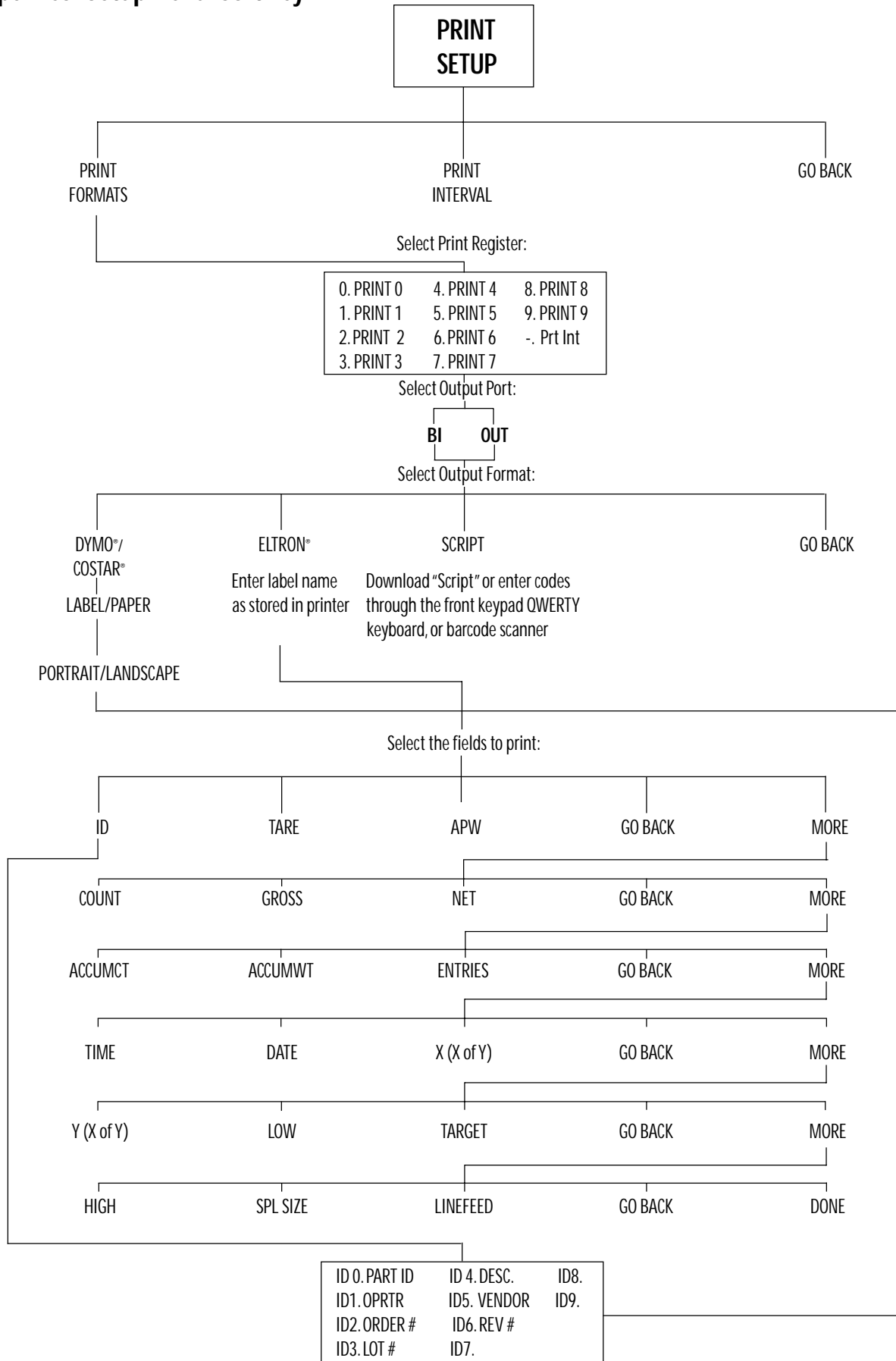

Soft Key:

# PRINT SETUP

## Setting Print Formats or Print Interval

This setup allows for the design of up to ten different label formats, as well as, setting up the interval printing function. There are three types of label formats available - the Dymo® SETRA 300 printer format, the Eltron printer format, and ScriptCoder. Each of these formats is detailed below.

The Dymo® SETRA 300 can print in English or barcodes. Straight ASCII text output is available by selecting "regular" size (vs. large print) which is compatible with any serial dot matrix printer.

The Eltron printer selection is only designed to work in conjunction with a label format created using the Eltron *Create-A-Label* software. The label format is stored in the printer's memory. When an Eltron label is printed, scale information is sent to the printer and combined with the label format in the printer.

For any other serial printer, a label design can be created using the ScriptCoder feature (see Appendix B for details).

To access the PRINT SETUP menu, either follow the menu tree or press the soft keys in the order listed below:

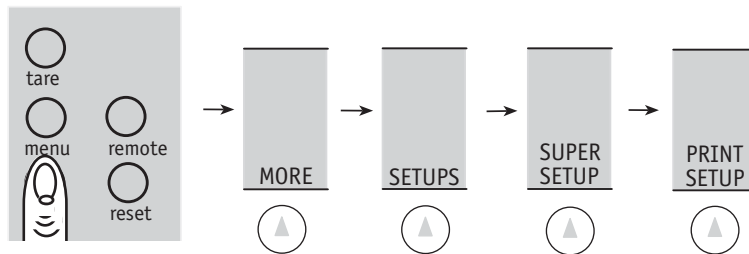

The soft keys will change to the following:

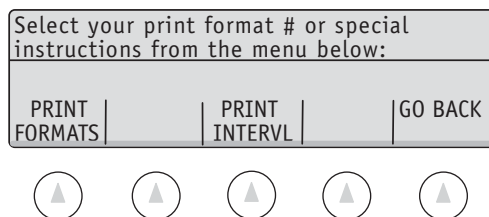

Select the function to program:

**PRINT FORMATS** allows the print registers to be configured.

**PRINT INTRVL** allows programming a print format to automatically print at regular time intervals.

## Programming a PRINT Format

Print Format Options: There are ten available formats that can be individually configured. Pressing the **PRINT FORMATS** soft key described previously will access the Print register selection menu.

Select Print Register:		
0. Print 0	4. Print 4	8. Print 8
1. Print 1	5. Print 5	9. Print 9
2. Print 2	6. Print 6	-. Prt Int
3. Print 3	7. Print 7	
NAME	ON/OFF	DELETE   # COPYS   GO BACK

▲ ▲ ▲ ▲ ▲

Select the **NAME** soft key to change the print format name (the title that appears in the above screen). Select **ON/OFF** to enable and disable the print format. Disabled print formats cannot be printed but retain their format information. Select **# COPYS** to program multiple label prints. After pressing **# COPYS** and selecting the print register to set up, the following screen is displayed:

Enter number of copies to be printed or VARIABLE to select number at print time:		
COPIES:1		
ENTER	VARIABLE	GO BACK

▲ ▲ ▲ ▲ ▲

Either enter the number of copies to be printed using the numeric keypad and press the **ENTER** soft key or press the **VARIABLE** soft key to allow the user to choose the number of copies when printing.

To program a print format, follow the steps below:

1. Using the numeric keypad, select the desired print register to program
2. Select the output port for the print format. This is the port into which the printer will be plugged.

Select the port for the printer output.		
BI	OUT	GO BACK

▲ ▲ ▲ ▲ ▲

3. Select the print format type:

Select your printer type:		
DYMO COSTAR	ELTRON	SCRIPT   GO BACK

▲ ▲ ▲ ▲ ▲

Based on the print format type selected, one of three series of screens appears:

## DYMO®\* Setra 300/COSTAR

- A. Select **LABEL** (ends with form feed) or **PAPER** printing (sends a line of dashes between printings).

Select your media type:		
LABEL	PAPER	GO BACK

- B. Choose label orientation as either **PORTRAIT** which limits the bar coded ID information to 9 characters when using the Setra control codes or **LANDSCAPE** which limits the bar coded ID information to 20 characters when using the Setra control codes. (See RS232 Communications in Appendix A for more information on Setra control codes).

Select print orientation:		
PRTRAIT	LNDSCPE	GO BACK

- C. Select a print field to appear on the label (see "Selecting Fields to Print", p. 15). After selecting a field to print, choose the output characteristics for that field.

Select the output for the field:				
SMALL ENGLISH	LARGE ENGLISH	BARCODE SC ENG	BARCODE SC LENG	BARCODE ENGLISH

**SMALL ENGLISH** is for the regular sized English text printing (straight ASCII text).

**LARGE ENGLISH** is for large English text printing (contains Dymo® control codes). Large text has twice the height of the small text, but the same width.

**BARCODE SC ENG** is for a bar coded field with the Setra control characters (see RS232 Appendix A) and regular size English

**BARCODE SC LENG** is for a bar coded field with the Setra control characters (see RS232 Appendix A) and large English text.

**BARCODE ENGLISH** is for a bar coded field without the Setra control characters and regular size English

\* Trademark of Dymo® Corporation

- D. After selecting and formatting all of the desired fields, select the **DONE** soft key at the end of the field selection menu (see “Selecting Fields to Print”, p. 15).

## ELTRON\*

- A. For the Eltron printer, type in the name of the label as stored in the printer with the *Create-A-Label* software by using the alphanumeric keypad (**abc** key) followed by the **ENTER** soft key.
- B. Next select the *Create-A-Label* “when printed” fields (see “Selecting Fields to Print”, p. 15 in the order they appear on the Eltron label as created with the *Create-A-Label* software.
- C. After choosing the last “when printed” field, select the **DONE** soft key at the end of the field selection menu (see next section). When printing an Eltron label, the Super II software recalls the label name as stored in the printer and then sends the appropriate “when printed” field information followed by the print command (see ScriptCoder Manual for more information on Eltron Create-A-Label formats).

**Warning:** When using this method, Setra Control Characters will NOT be sent. If you need to send Setra Control Characters, you need to use the Scriptcoder program (see Appendix B: Scriptcoder Custom Label Printing).

## SCRIPTCODER

ScriptCoder is a powerful scripting language that allows the user to program the print register a single character at a time. There are four methods of data entry for a script. Please refer to Appendix B or the ScriptCoder Manual for a detailed explanation of each method of data entry and scripting language.

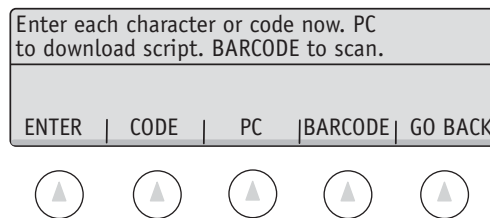

\*Eltron® is a registered trademark of Zebra Corporation

## Selecting Fields to Print

The following is a list of all scale fields available for printing. The fields can be printed in any order selected. Move up and down through the menus by using the GO BACK and MORE keys.

Select the desired fields to print from the menu below:

ID	TARE	APW	GO BACK	MORE
				

(will bring up all ID fields listed below)





COUNT	GROSS	NET	GO BACK	MORE
				





ACCUMCT	ACCUMWT	ENTRIES	GO BACK	MORE
				





(for an accumulated count)

(for an accumulated weight)

(for the number of accumulated entries)

TIME	DATE	X(X of Y)	GO BACK	MORE
				

Y (X of Y)	LOW	TARGET	GO BACK	MORE
				

HIGH	SPLSIZE	LINEFED	GO BACK	DONE
				

(for the sample size used to determine the APW)

(for spacing between fields)

(to end print format)

## ID Fields

ID field selection will bring up the following menu.

Select ID Field:		
ID0: PART ID	ID4: DESC	ID8:
ID1: OPRTR	ID5: VENDOR	ID9:
ID2: ORDER #	ID6: REV #	
ID3: LOT #	ID7:	
		GO BACK

▲ ▲ ▲ ▲ ▲

Select the desired ID field to print by entering the numeric ID# associated with that field using the numeric keypad.

The "identifier" associated with each field will print before the variable ID information as it appears in the choices above for the Dymo® format. The identifier can be changed to any 7 characters desired.

To change the field identifier name, see the **ID NAME** soft key section starting on page 41.

NOTE: The database uses the ID0 field for storage indexing. It is recommended that the PART ID be used for the ID0 field. LOT# (ID3) and DESC (ID4) correspond to the same scale ID locations as in Setra's AutoCount 200 for backward compatibility purposes.



## Interval Print Programming

Any of the ten print formats can be selected for interval printing. Selecting "No Format" will send the displayed weight or count value to the BI port. The interval print function is set up by selecting the **PRINT INTERVL** soft key in the Print setup. The following display will appear:

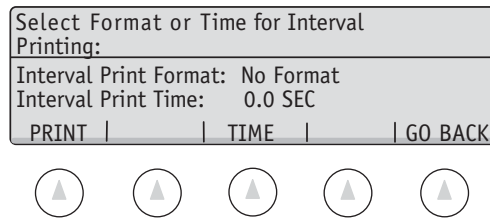

The currently selected format as well as the Time Interval between printings is displayed. Note that the time interval of 0.0 means that the internal print function is disabled. The interval printer will wait for the last printing job to finish before starting the next. If a small interval is selected, the port will continuously stream data. Select the **PRINT** soft key to set up the print format and the **TIME** soft key to select the time between printings.

If the **PRINT** soft key is selected, the following screen appears:

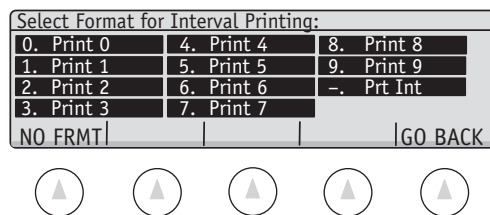

Select one of the preprogrammed print registers using the numeric keypad, or the **NO FRMT** soft key to have the scale print the weight or count in the immediate Print Mode format. (Appendix A)

If the **TIME** soft key is selected:

Select from either the two pre-programmed choices or, using the numeric keypad, enter a time interval followed by the **ENTER** key. Once the time interval is programmed, interval printing is stopped or started by selecting the Prt Int register through the - (minus) key in the print menu.

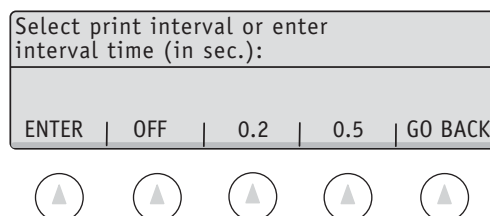

NOTE: The maximum output rate is every 0.2 seconds.

## Supervisor Setup Menu: Soft Key SAMPLE SETUP

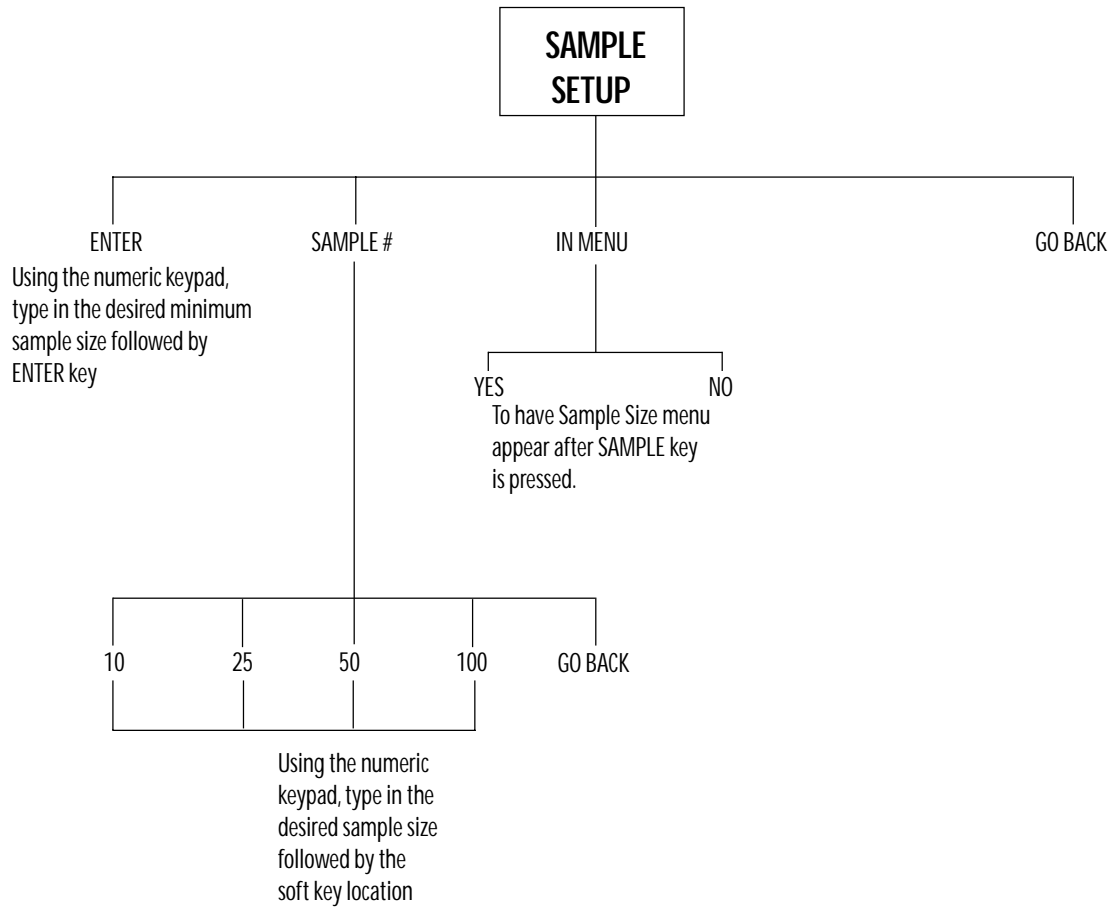

## SOFT KEY:

# SAMPLE SETUP

## Setting a Minimum Sample Size/Sample Size Selection Menu

This setup allows a selection of a minimum number of pieces that can be used to generate an APW. Also available is the capability to have the scale create a prompt for multiple sample size selections that can be customized to whatever the operator needs.

To access the SAMPLE menu, either follow the menu tree or press the soft keys in the order listed below:

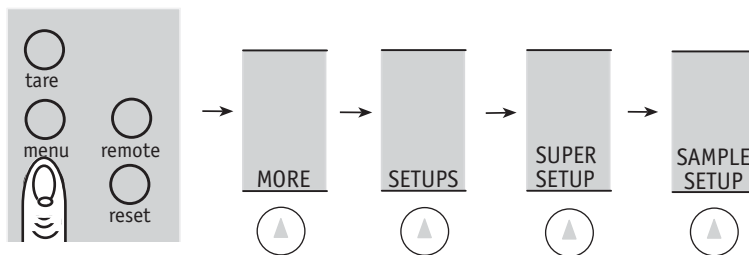

The soft keys will change to the following:

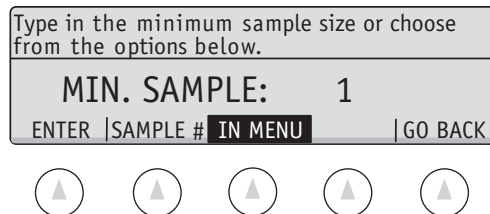

1. To set the minimum sample size, use the numeric keypad and type in the desired number followed by the **ENTER** key.
2. To change the sample size if the sample size > 10 in the series of prompts when the **LRG SPL** key is pressed in the default user menu, choose **SAMPLE #**. Change each prompt to any desired value by using the numeric keypad followed by the soft key for the number to be changed.
3. To have sample size choices appear in the main menu when the **SAMPLE >** key is pressed, choose the **IN MENU** key followed by the **YES** key. The "sample size menu" choice can be turned off by pressing the **IN MENU** key followed by the **NO** key.

## Supervisor Setup Menu: Soft Key ACCURCY SETUP

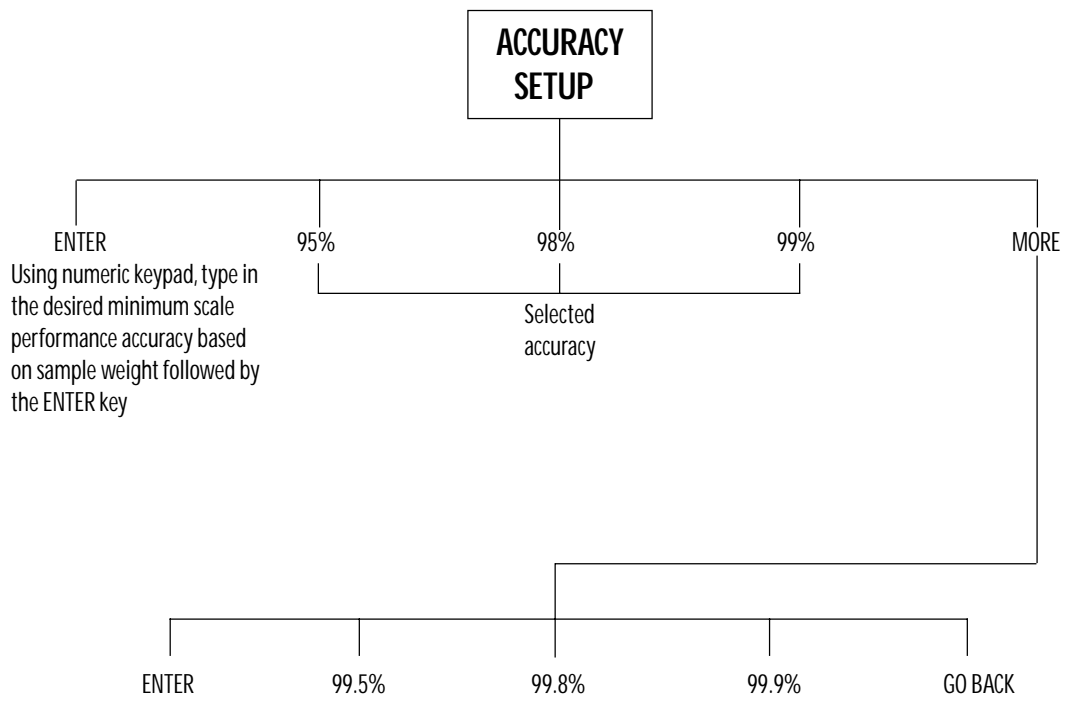

## SOFT KEY:

# ACCURACY SETUP

## Setting a Minimum Scale Performance Accuracy

This setup allows selection of the minimum accuracy level to which the scale will perform based on the sample weight. The higher the scale performance, the larger the sample weight required. This may cause the scale to prompt for additional pieces when the **COUNT** key is pressed to meet the minimum weight requirement to perform to the programmed accuracy level.

**IMPORTANT:** This setup does not take individual piece weight variance into account and only has to do with sample weight. The scale must also be programmed with a large enough minimum sample size to guarantee performance based on piece weight variance.

To access the ACCURACY menu, either follow the menu tree or press the soft keys in the order listed below:

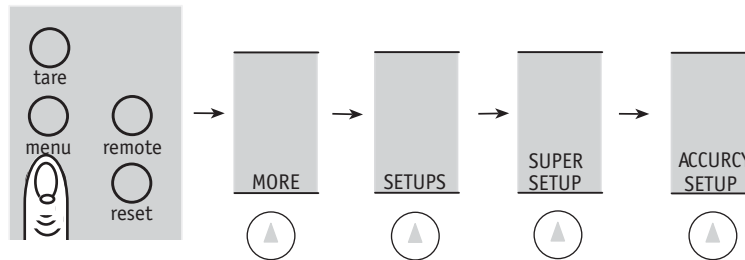

Using the numeric keypad, type in the desired Minimum Scale Performance Accuracy followed by the **ENTER** key or choose from the soft key selections available and listed below.

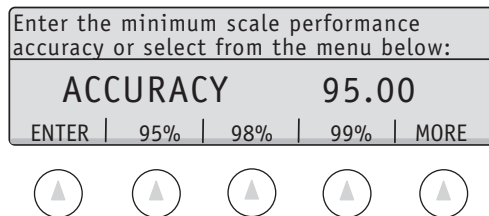

Additional selections are available by pressing the **MORE** soft key.

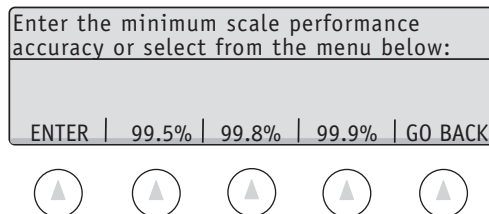

Either type in the desired Minimum Scale Performance Accuracy followed by the **ENTER** soft key or choose from the selections available.

# Supervisor Setup Menu: Soft Key PORTS SETUP

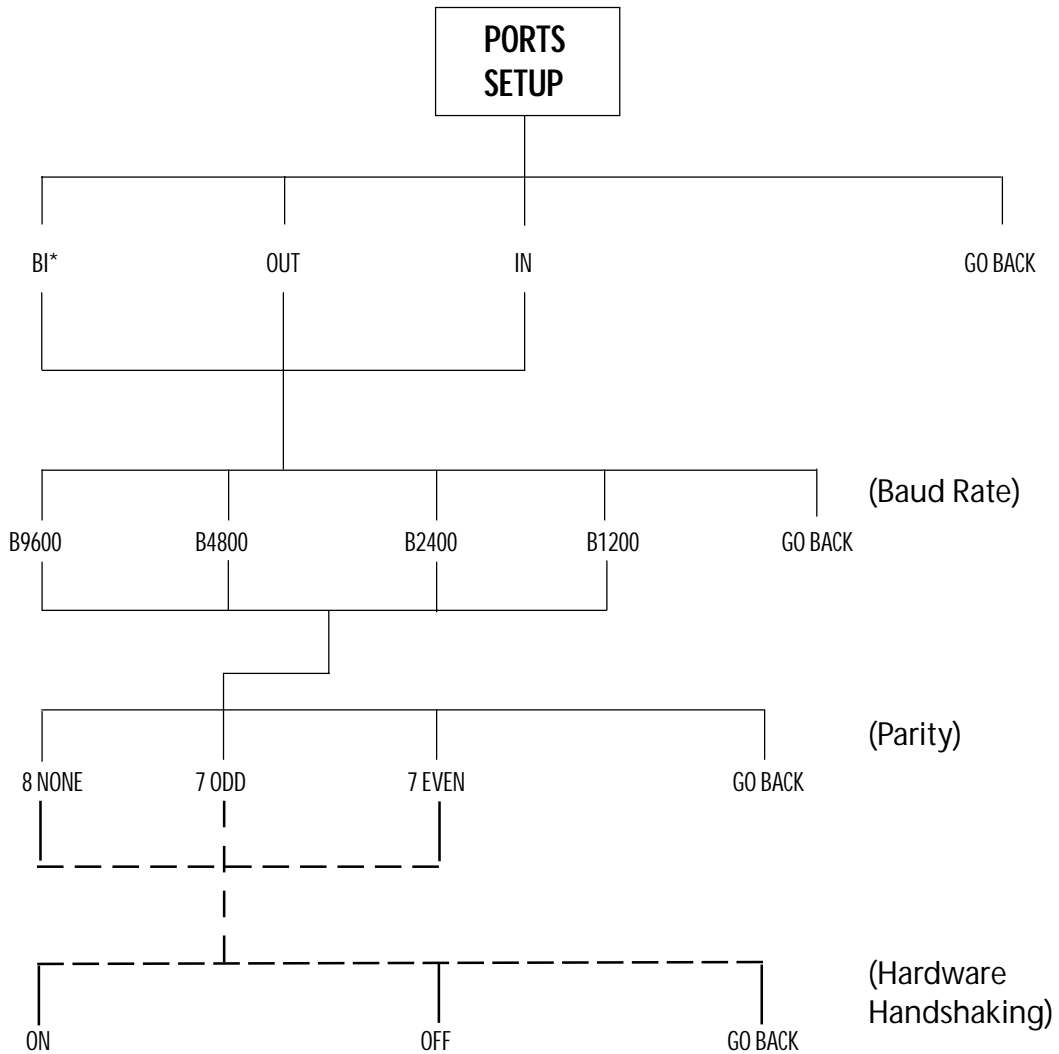

\* Hardware handshaking available on the BI port only

## SOFT KEY:

# PORTS SETUP

## Programming the RS232 Settings

This setup allows selection of the settings for the three RS232 communication ports.

The factory default setting for the BI port is 9600 baud, 8 databits, no parity with hardware handshaking on. For the IN and OUT ports, the factory default is 2400 baud, 8 databits, and no parity.

To access the RS232 menu, either follow the menu tree or press the soft keys in the order listed below:

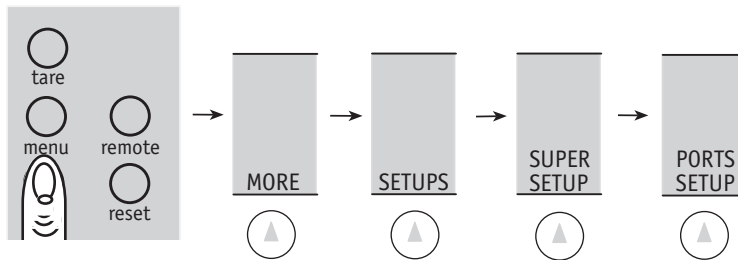

1. Choose the RS232 port to configure.

Select the port to configure:

BI	OUT	IN		GO BACK
----	-----	----	--	---------

▲ ▲ ▲ ▲ ▲

2. Choose the baud rate.

Select the baud rate:

B9600	B4800	B2400	B1200	GO BACK
-------	-------	-------	-------	---------

▲ ▲ ▲ ▲ ▲

3. Choose the databit/parity setting.

Select the character format/byte size:  
Note: IN & OUT ports share a common byte

8NONE	7ODD	7EVEN	GO BACK
-------	------	-------	---------

▲ ▲ ▲ ▲ ▲

4. For the BI port only, choose to have hardware handshaking ON or OFF. Handshaking must be ON for SuperTalk, OFF for Scriptcoder.

Select enabling of hardware handshaking:

ON		OFF	GO BACK
----	--	-----	---------

▲ ▲ ▲ ▲ ▲

# Supervisor Setup Menu: Soft Key TIME DATE

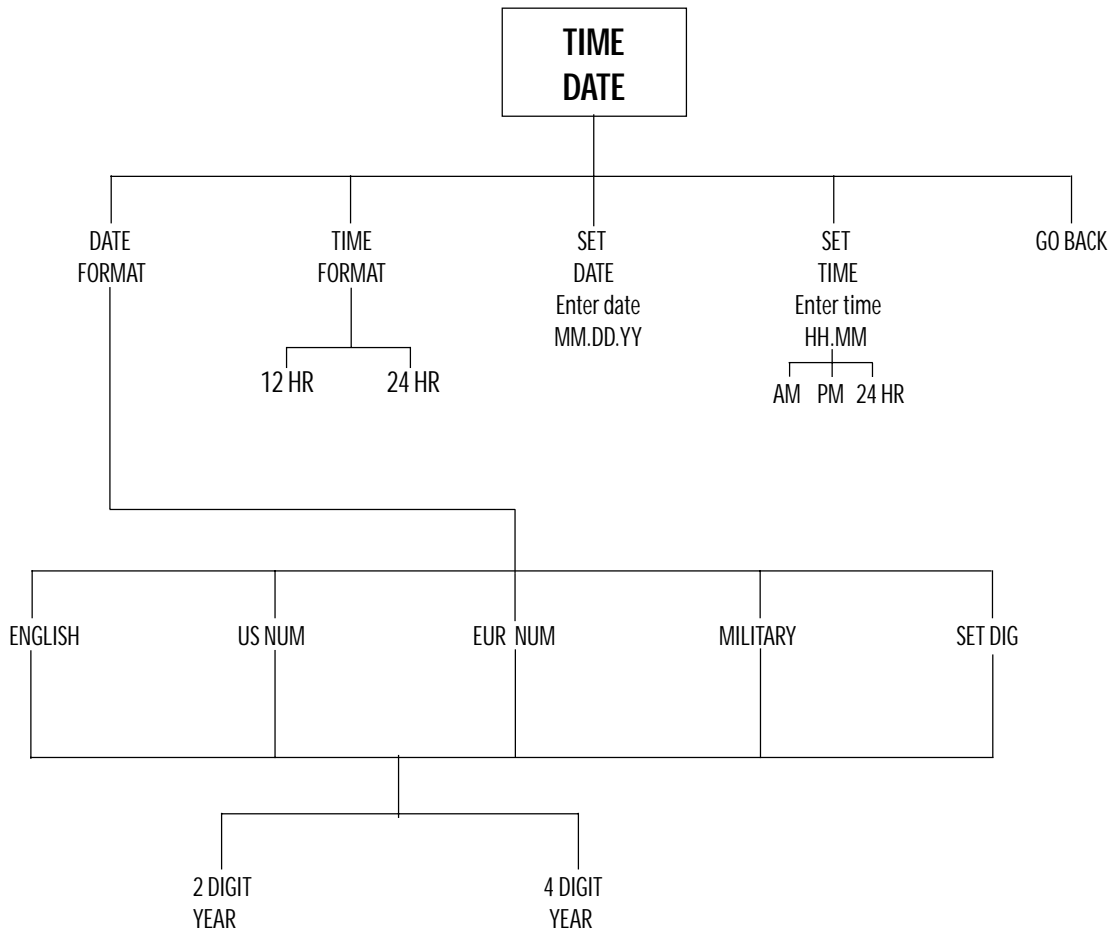



## SOFT KEY:

# TIME DATE

## Programming the Time Date Reporting

This setup allows setting the time and date for the scale as well as choosing the format for reporting the time and date. For example, time can be reported in either 12 or 24 hour format and the year can be reported as either 4 digits (e.g., "2001") or 2 digits (e.g., "01")

Note: The factory default reports the date in US MM/DD/YYYY and the hour in 12 hour time format.

To access the TIME DATE menu, either follow the menu tree or press the keys in the order listed below.

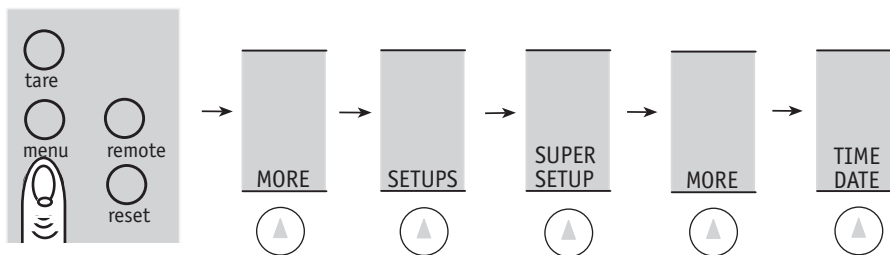

Choose from the options below:

Select from the options below to set up the time and date:				
DATE FORMAT	TIME FORMAT	SET DATE	SET TIME	GO BACK
▲	▲	▲	▲	▲

### DATE FORMAT

The date can be printed in four different formats. **ENGLISH** spells out the month in English. The numeric date reporting can be in U.S. format (**US NUM**) or European format (**EUR NUM**). **MILITRY** reports the date in the military format. Choose from the available options:

Choose the print format for the month:				
ENGLISH	US NUM	EUR NUM	MILITRY	SET DIG
▲	▲	▲	▲	▲

ENGLISH	DATE:	February 5, 2004
US NUM	DATE:	2/05/2004
EUR NUM	DATE:	5/02/2004
MILITRY	DATE:	5 FEB 2004

Select **(SET DIG)** to print the year in either 2 digit or 4 digit format.

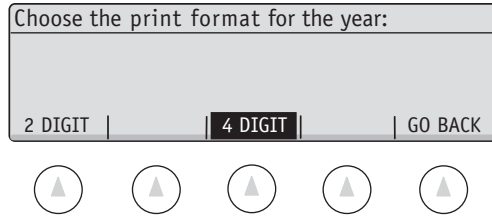

### TIME FORMAT

The time can be printed in either 12 hour or 24 hour format. Choose from the options below:

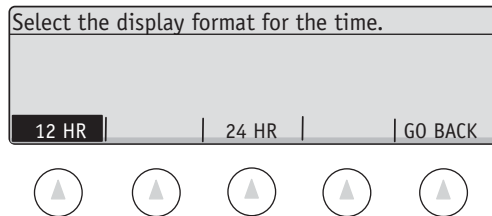

### SET DATE

Using the numeric keypad, type in the date in the format, MM.DD.YY, followed by the **ENTER** key:

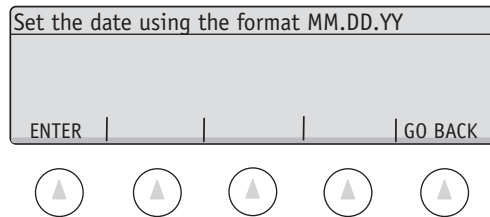

### SET TIME

Using the numeric keypad, type in the time in the format, HH.MM, followed by a selection for **AM**, **PM**, or **24 HR** key.

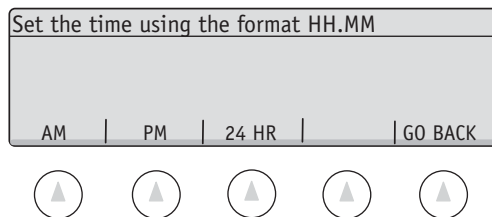

NOTE: When setting Time and Date format "." (period) is critical.



## Supervisor Setup Menu: Soft Key UNITS ON

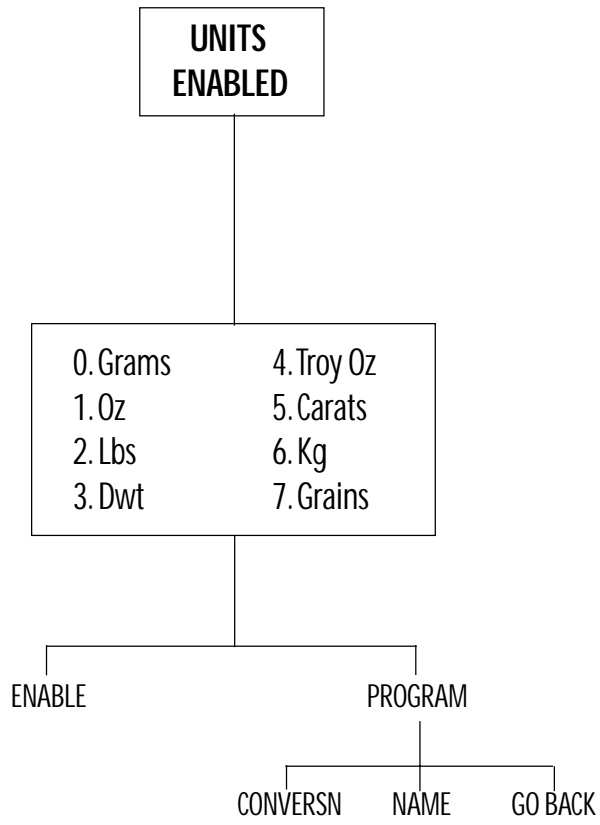

## SOFT KEY:

# UNITS ENABLED

## Selecting Weighing Units

This setup allows selection of units of measure available in the **UNITS** soft key menu in the User Functions (See User's Manual). In addition, the last unit of measure (**7. GRAINS**) is a user definable unit of measure, sometimes referred to as 'x'units. For the user definable unit, the conversion factor and the name of the unit can be customized.

Note: The factory default is to have all units available and the user definable unit set to GRAINS.

To access the UNITS ENABLED menu, either follow the menu tree or press the keys in the order listed below:

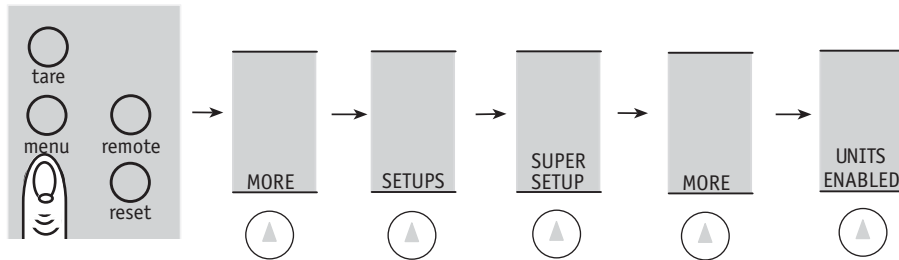

1. To toggle the availability of a unit of measure, select **ENABLE** then that unit of measure by number. Units that are not available to the user are shown in reverse video.

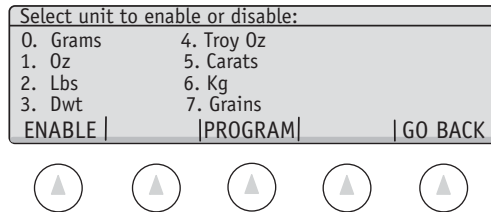

## Programming the User Definable Unit of Measure

To program the user definable unit( default GRAINS), choose **PROGRAM** , name the unit and enter conversion factor.

Enter the details of the selected unit:		
User Unit Name: Grains		
User UNit Conversion: 15.4324/gram		
CONVRSN	NAME	GO BACK

▲ ▲ ▲ ▲ ▲

- a. **CONVERSION:** Press **CONVRSN** and then, using the scale keypad, enter the conversion number for grams; then choose either **FACTOR** (multiplier) or **DIVISOR**.

Enter the conversion factor (x) or divisor (/) from grams:		
FACTOR	DIVISOR	GO BACK

▲ ▲ ▲ ▲ ▲

- b. **NAME:** Using the alphanumeric keypad (**abc** key), enter the unit name (limited to six characters) followed by the **ENTER** key.

Enter the unit name:		
ENTER		GO BACK

▲ ▲ ▲ ▲ ▲



# Supervisor Setup Menu: Soft Key DATABASE SETUP

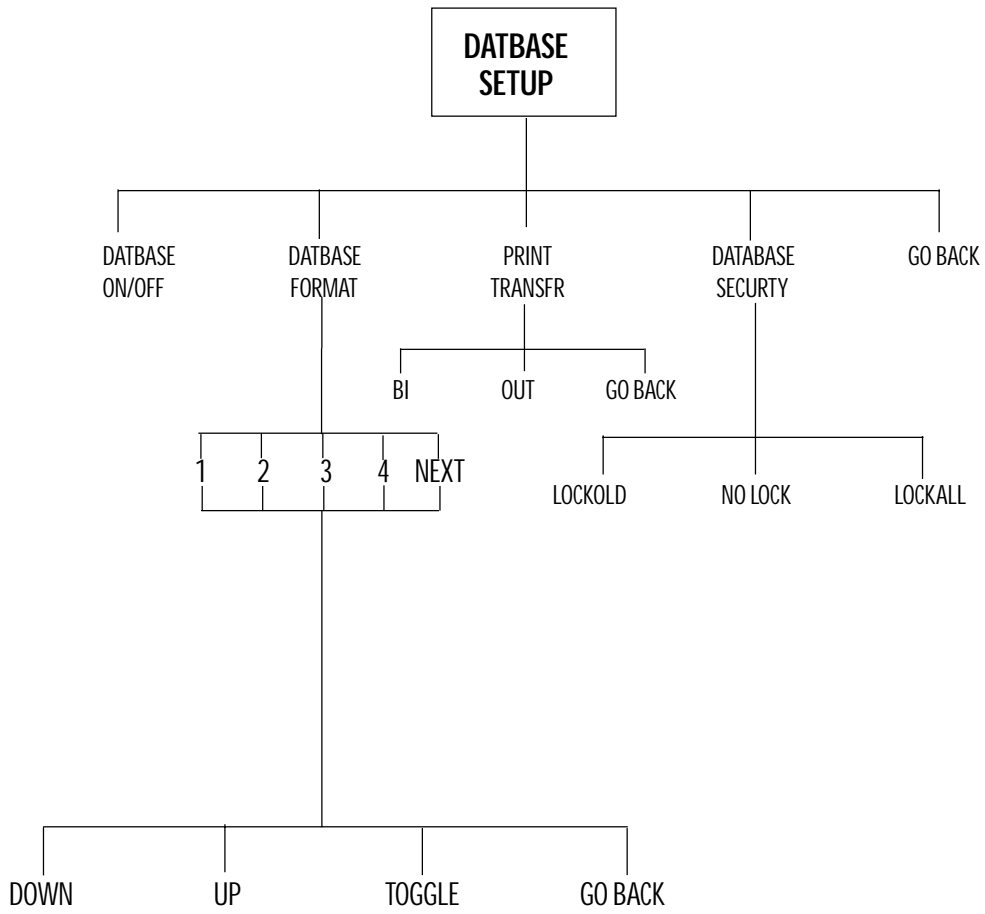



SOFT KEY:

# DATABASE SETUP

## Setting up the Database Format, Printing/Transferring the Database Information, and Setting the Database Security

The controller has memory for a database which has a number of configurations. The database can contain two different types of records: database records and transactions. Database records contain stocking information and can be recalled using the PART ID (IDØ). Transactions are stored and accessed sequentially and each contains information about a single event or action performed on a single part. The database can hold both database records and/or transactions. See TRANSAC SETUP for details about Transaction log records and setups.

Database records and transactions are made up of fields of information. The records are comprised of any of the following fields:

### DATABASE:

ID 0: PART ID  
ID 1: OPRTR  
ID 2: ORDER #  
ID 3: LOT #  
ID 4: DESC  
ID 5: VENDOR  
ID 6: REV #  
ID 7:  
ID 8:  
ID 9:

GROSS:  
NET:  
ACC WT:  
TARE:  
APW:  
COUNT:  
ACC COUNT:  
ACC ENTS:  
LOW:  
TARGET:  
HIGH:

TIME:  
DATE:

The PART ID (IDØ) is used to index database records. When entering records into the database, the PART ID (IDØ) must be non-empty and unique.

To access the DATABASE SETUP menu, either follow the menu tree or press the soft keys in the order listed below:

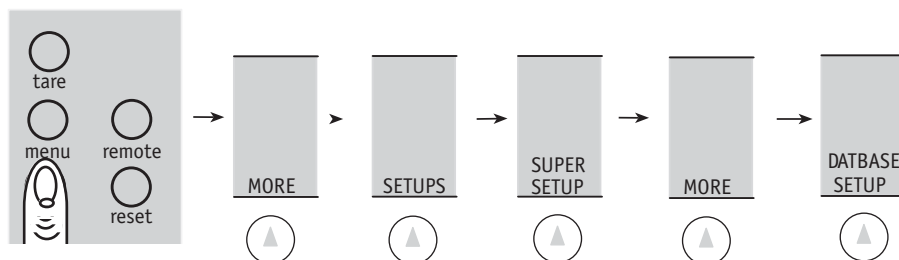

1. Any combination of fields may be used as long as it contains ID0. As more fields are added, each record grows in length, reducing the total number of available stored records.

The following menu is displayed and the soft keys change to:

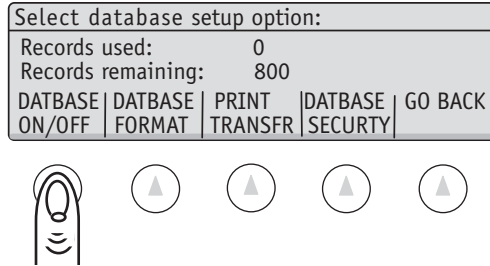

Select **DATABASE ON/OFF** to toggle the availability of the database. When off, the **SAVE** and **DATABASE** keys in the User's menu will not allow the user to store and view the database records (although these keys may give access to the transaction log if it is on). In default, the database is off.

Select the **DATABASE FORMAT** soft key for programming the database format. The following menu and soft keys appear:

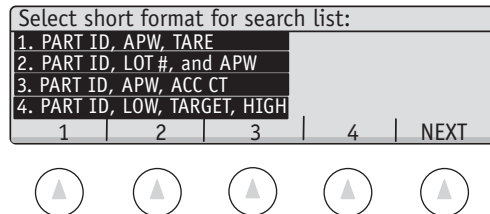

Select the desired database list format by pressing the soft key for the number corresponding to the format most appropriate. This selection will affect the behavior of the **DATABASE** soft key in the User's menu.

Next, select the fields to be stored in the database:

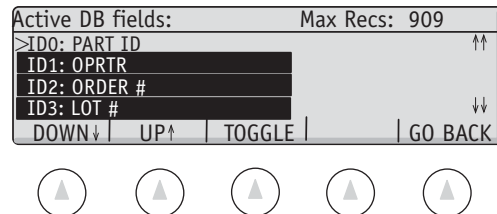

1. Move the cursor up and down using the **DOWN** and **UP** keys.
2. Turn a field on or off by placing the cursor next to it and pressing the Toggle button. Fields that are turned off are shown in inverse text. The double arrows on the right side of the screen indicates that more fields are available, up or down.
3. As fields are turned on, each record grows in size. The number of records that may be stored with a particular configuration is shown in the prompt line as "Max. Recs xxx". Please note that this number is generated assuming that the transaction log is off. The maximum number of stored database records may be significantly lower if the transaction log is on.
4. The double arrows on the right side of the screen indicate that more fields are available up or down.

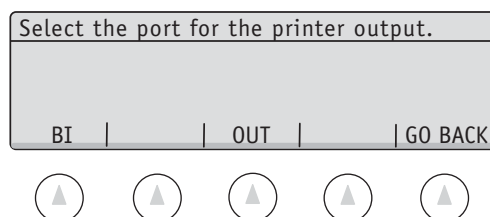

Approximate number of orders which can be stored are:

Part ID and APW	2183
Part ID, APW & Tare	1926
Part ID, Desc & APW	1364

Select **DATABASE SECURITY** to change the user access to the database records.

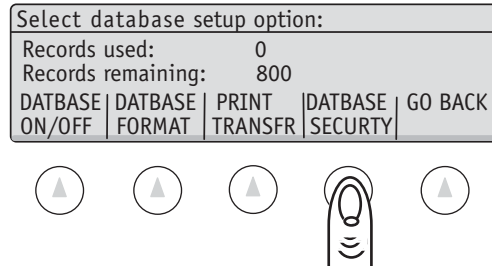

The following menu and soft keys will appear:



**LOCK OLD:** Prevents a user from making any changes or deletions to a saved record in the database. However, new records can be added to the database.

**NO LOCK:** Allows full access to the database for changes, deletions and additions.  
(Default)

**LOCK ALL:** Prevents any changes, deletions and additions to the database.

## Supervisor Setup Menu: Soft Key TRANSAC SETUP

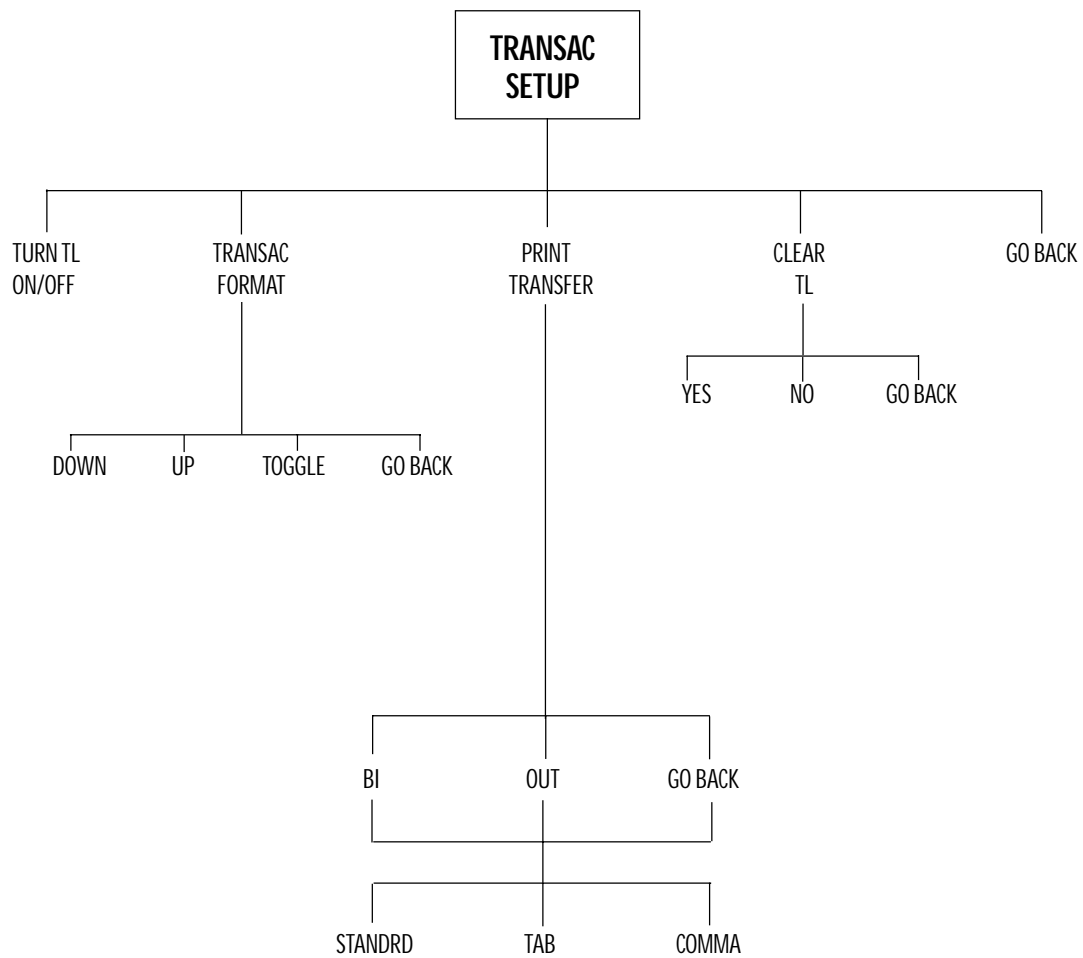

## SOFT KEY:

# TRANSAC SETUP

## Setting up the Transaction Log format, Printing/Transferring the Transactions and Clearing the Transaction Log

The controller has memory for an extensive database which has a number of configurations. The database can contain two different types of records: database records and transactions. Database records contain stocking information and can be recalled using the PART ID (IDØ). Transactions are stored and accessed sequentially and each contains information about a single event or action performed on a single part. The database can hold both database records and/or transactions. See DATABASE SETUP for details about setting and using database records.

Database records and transactions are made up of fields of information. The records are comprised of any of the following fields:

### DATABASE:

ID 0: PART ID	GROSS:	TIME:
ID 1: OPRTR	NET:	DATE:
ID 2: ORDER #	ACC WT:	
ID 3: LOT #	TARE:	
ID 4: DESC	APW:	
ID 5: VENDOR	COUNT:	
ID 6: REV #	ACC COUNT:	
ID 7:	ACC ENTS:	
ID 8:	LOW:	
ID 9:	TARGET:	
	HIGH:	

Any of the fields may be enabled or disabled. A disabled field will not be stored, displayed or printed.

To access the **TRANSAC SETUP** menu, either follow the menu tree or press the keys in the order below:

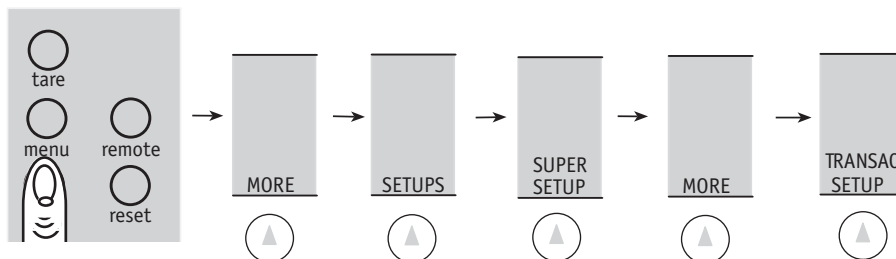

The following menu appears and the soft keys change to:

Select Transaction Log setup option:				
Records used:	0			
Records remaining:	909			
TRN LOG	TRANSAC	PRINT	CLEAR	GO BACK
ON/OFF	FORMAT	TRANSFR	TRN LOG	



The "Records Used" field shows how many transactions are currently stored in the transaction log. The "Records Remaining" shows how many more records can be stored in the database. The "Records Remaining" depends on the number of transactions and database records currently stored and the size of the individual transaction record (The number of fields turned on).

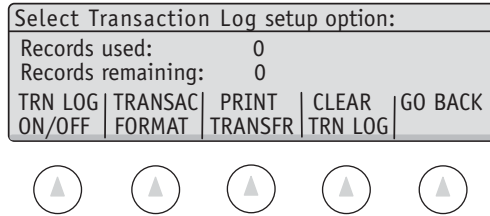

Select the **TRN LG ON/OFF** soft key to activate the Transaction Log. When the Transaction Log is off, access to the saving, viewing, and printing screens are disabled but the format is retained.

Next select the fields to be stored in a transaction log record by selecting 'TRANSAC FORMAT'

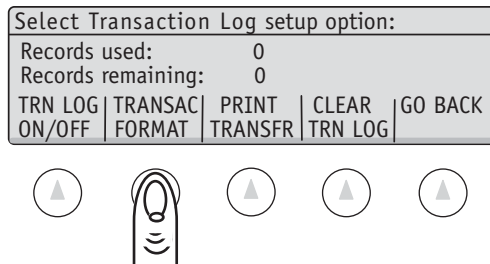

The following menu appears:

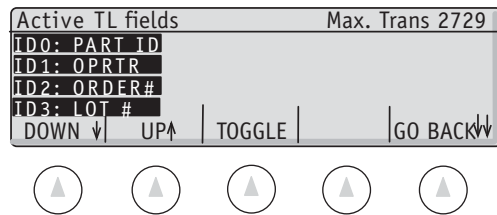

1. Move the cursor up and down using the **DOWN** and **UP** keys.
2. Turn a field on or off by placing the cursor next to it and pressing the Toggle button. Fields that are turned off are shown in inverse text. The double arrows on the right side of the screen indicates that more fields are available, up or down.
3. As fields are turned on, each transaction will use more memory space. The number of records that may be stored with a particular configuration is shown in the prompt line. Please note that this number is generated assuming that the transaction log is off. The maximum number of stored database records may be significantly lower if the transaction log is on.
4. The double arrows on the right side of the screen indicate that more fields are available up or down.

The approximate number of transactions stored depends upon the fields you select. This table illustrates the number of transactions possible to store:

<u>FIELDS SELECTED</u>	<u>NUMBER OF TRANSACTIONS</u>
ID0: PART ID	2729
ID0: PART ID, COUNT	2339
ID0: PART ID, ID3:LOT#, & COUNT	1423
ID0: PART ID, COUNT, & DATE	1423

The following menu appears:

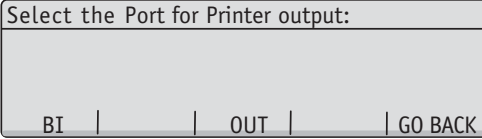

Select the Port for Printer output:

BI | | OUT | | GO BACK

▲ ▲ ▲ ▲ ▲

Select a port. The following menu appears:

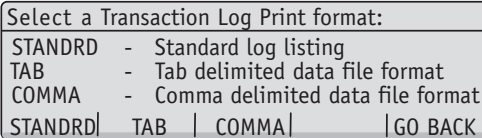

Select a Transaction Log Print format:

STANDRD - Standard log listing  
TAB - Tab delimited data file format  
COMMA - Comma delimited data file format

STANDRD | TAB | COMMA | | GO BACK

▲ ▲ ▲ ▲ ▲

Choose a print format and the data will be printed. Note that standard log listing will print a label for each record which is convenient for printed reports but of marginal use for computer data capture. Tab and comma formats are used for exporting the data to a computer.

Press **CLEAR TL** to erase all the transactions stored in the Transaction Log.

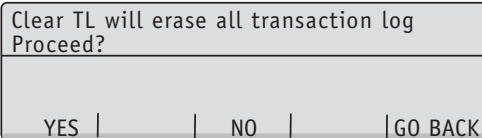

Clear TL will erase all transaction log  
Proceed?

YES | | NO | | GO BACK

▲ ▲ ▲ ▲ ▲

Press **YES** to proceed with erasing the transaction log.

## Supervisor Setup Menu: Soft Key ID NAME SETUP

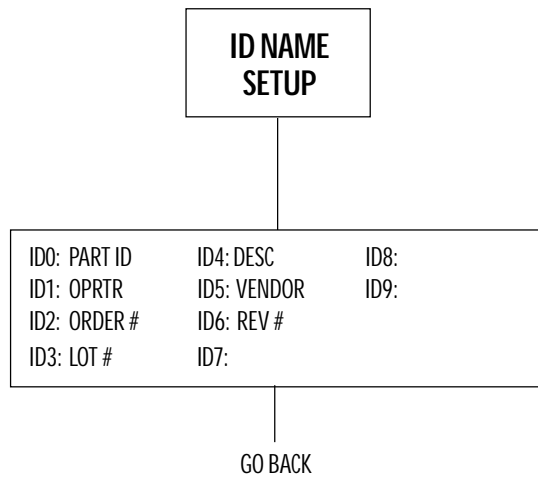



## SOFT KEY:

# ID NAME SETUP

## Changing the Name of the ID Fields

This setup allows changes to be made to the name of the ID fields. There are ten ID fields available for storage of information, for printing or for database usage. ID fields ID0 through ID6 have already been named with some of the most popular uses for scale transactions. All of the fields are available for renaming to any seven character descriptions.

Beware of making changes that would cause incompatibility with multi-scale systems or with older Setra scale systems. The ID0 field is the PART ID field and is used to reference all of the information in the database records. It is strongly recommended that the ID0 field always remains the PART ID or PART # field. The ID3: LOT# field and ID4: DESC (description) field are fields that have been named in those particular places for backward compatibility to Setra's Auto Count™200 system.

All other fields can be used for any other purpose. Each of the ID fields is either volatile or non-volatile. The non-volatile ID fields remain in the scale's memory until DELETED or changed. The volatile ID fields are only temporary registers that get cleared every time the **reset** key is pressed. The recommendation is to use the non-volatile ID registers for repetitive fields such as OPERATOR NAME or VENDOR NAME that do not require re-entry for every transaction.

The volatile and non-volatile fields are divided as follows:

### VOLATILE

ID0: PART ID  
ID2: ORDER #  
ID3: LOT #  
ID4: DESC  
ID6: REV#

### NON-VOLATILE

ID1: OPRTR  
ID5: VENDOR  
ID7:  
ID8:  
ID9:

To access the ID NAME SETUP menu, either follow the menu tree or press the keys in the order listed below.

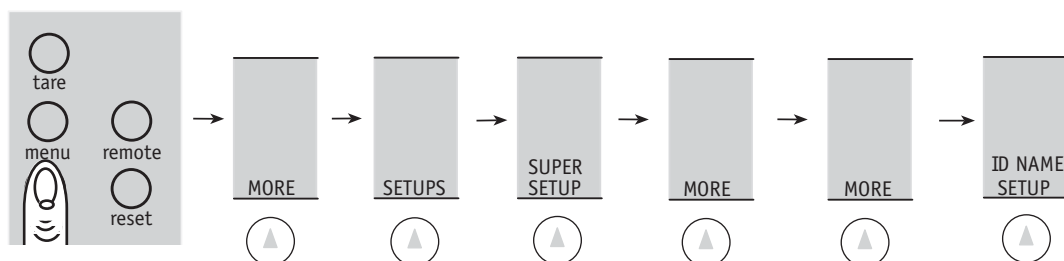

The following menu will appear:

Select ID Field to Name:		
ID0: PART ID	ID4: DESC	ID8:
ID1: OPRTR	ID5: VENDOR	ID9:
ID2: ORDER #	ID6: REV #	
ID3: LOT #	ID7:	
		GO BACK

▲ ▲ ▲ ▲ ▲

Using the numeric keypad, enter the number of the desired ID field name to be changed.

Enter new name, followed by the Enter.		
ENTER		GO BACK

▲ ▲ ▲ ▲ ▲

Using the alphanumeric keypad (**abc** key) or PC keyboard, enter up to 7 characters of the new name for the ID field followed by the **ENTER** soft key.



# Supervisor Setup Menu: Soft Key MACRO SETUP

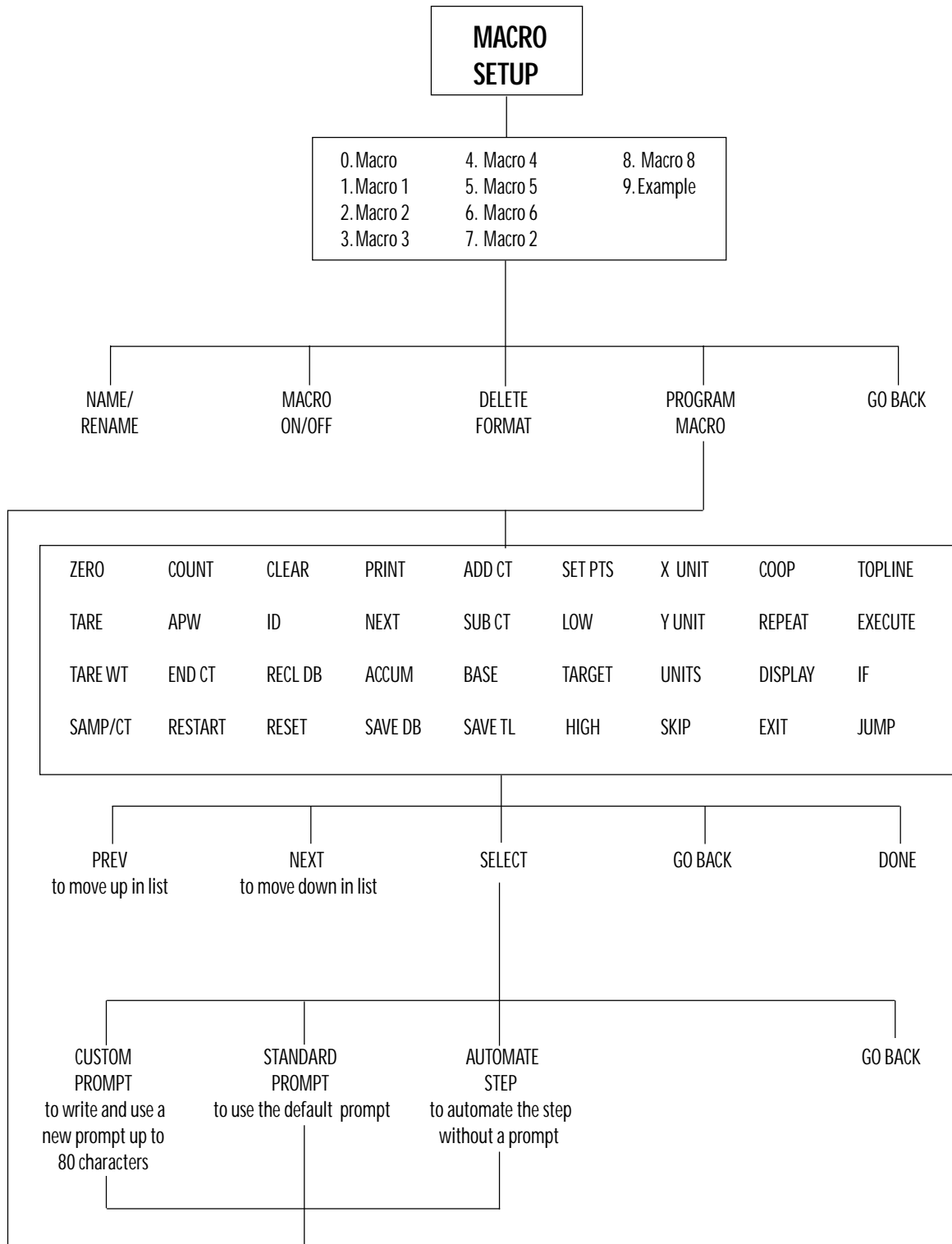

## SOFT KEY:

# MACRO SETUP

## Customizing Scale Operation & Prompting Sequences

This setup allows creation of a custom scale operation sequence. The sequence called a MACRO is programmed by the supervisor using pre-defined steps. Each step is comprised of three elements.

1. A prompt that can be written by the programmer
2. A soft key which is defined by the step function.
3. A function to be performed by the scale which is selected by the programmer.

When a macro is run by the user, the steps are displayed by the scale sequentially bringing the user through an entire operation.

Up to 10 macros containing a maximum of 100 steps total may be programmed into the scale. Pressing the **MACRO** softkey will run a macro that is programmed. If more than one macro is programmed and enabled, a selection screen is displayed. Please note that if only Macro 0 is enabled, it will run on power up and cannot be exited, allowing the supervisor to change the default operation of the scale.

To access the MACRO SETUP menu either follow the menu tree or press the keys in the order listed below:

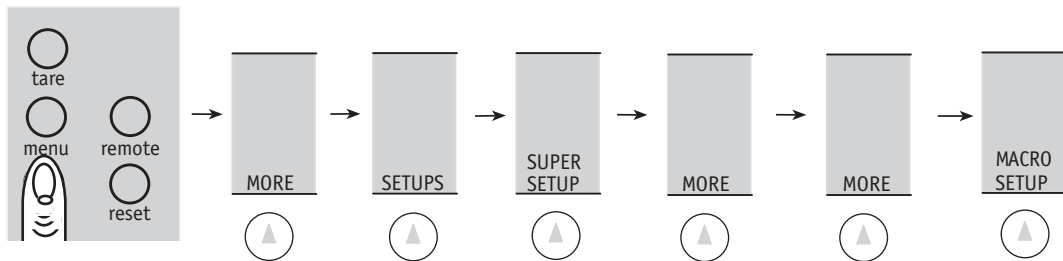

The following menu appears:

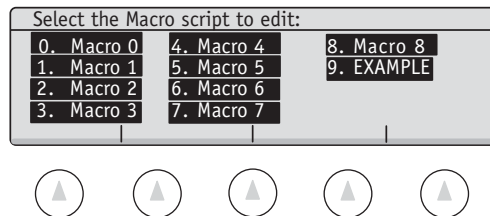

Using the numeric keypad, select the Macro (0-9) to edit.

Once the macro position has been selected, the soft keys change to the following:

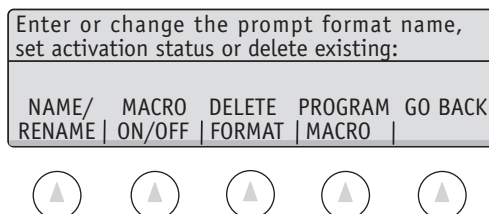

- NAME/RENAME** To customize the name of a Macro (up to 7 characters) and help identify its function when it appears in the Macro Selection Menu. Some possible examples are RECEIVE for a receiving function or KIT#123 for a special bagging operation.
- MACRO ON/OFF** To turn on or to turn off access to the Macro.
- DELETE FORMAT** To delete the programmed steps in the Macro.
- PROGRAM MACRO** To select the steps for the Macro.

### Programming a Macro

1. After selecting the **PROGRAM MACRO** soft key in the previous menu, the top of the long list of possible scale functions appears with the following soft keys:

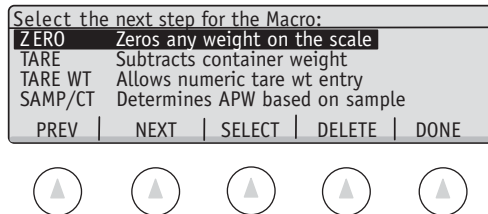

2. To scroll through the list of scale functions, use the **PREV**(previous) and **NEXT** soft keys. The list of scale functions is on the following pages.
3. To select the highlighted scale function as the next step in the macro, press the **SELECT** soft key. The default prompt associated with that key name and function will appear and the soft keys change to the following:

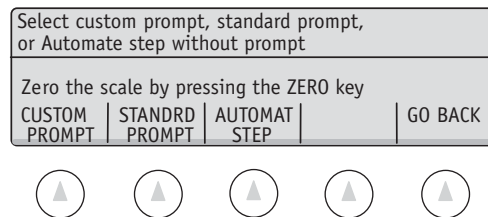

- A. To use the default prompt, press the **STANDRD PROMPT** soft key and the program will return to the scale function selection menu (step 1).
- B. To program a custom prompt associated with that key name and function, press the **CUSTOM PROMPT** soft key. The menu will change; type in a prompt of up to 80 characters using the scale's alphanumeric keypad (**abc** key) or an attached QWERTY keyboard.
- C. To automate the step without a prompt, press the **AUTOMAT STEP** soft key. An automated step will process the scale function without waiting for user input.

4. To erase the last selected step in the macro, press the **DELETE** soft key. If all the steps are erased, the previous screen is displayed.
5. After selecting the last step in the macro, press the **DONE** soft key.

**MACRO STEPS:**

<b>NAME</b>	<b>FUNCTION</b>	<b>PROMPT</b>
<b>ZERO</b>	Zeros any weight on the scale	Zero the scale by pressing the <b>ZERO</b> key.
<b>TARE</b>	Subtracts container weight	Place an empty container and press the <b>TARE</b> key.
<b>TARE WT</b>	Allows numeric tare weight entry	Enter the tare weight and press the <b>TARE WT</b> key.
<b>SMPL/CT</b>	Determines APW based on sample	Add sample and press the <b>SMPL/CT</b> key.
<b>COUNT</b>	Switches to the count mode	Press the <b>COUNT</b> key to switch to the count mode.
<b>APW</b>	Allows numeric APW entry	Enter the Average Piece Weight and press the <b>APW</b> key.
<b>ENDCT</b>	Prompts to end counting	Add pieces until done and press the <b>ENDCT</b> key.
<b>RESTART</b>	Returns to beginning of macro	Press the <b>RESTART</b> key to start over.
<b>CLEAR</b>	Changes from Count to Weight	Press the <b>CLEAR</b> key to return to weight.
<b>ID</b>	Enters data into ID register	Prompts for selected ID field.
<b>RECL DB</b>	Recalls record from database	Enter ID # and press the <b>RECL DB</b> key to recall the record from the database.
<b>RESET</b>	Clears all and resets macro	Press the <b>RESET</b> key to clear all registers and begin again.
<b>PRINT</b>	Prints labels	Press the <b>PRINT</b> key. (For selected print format)
<b>NEXT</b>	Entry for any non-scale step	Do your non-scale related step and press the <b>NEXT</b> key to continue.
<b>ACCUM</b>	Adds display to accumulator	Press the <b>ACCUM</b> key to add to the Accumulator register.
<b>SAVE DB</b>	Saves the record to database	Press the <b>SAVE</b> key to save the record to the database.
<b>ADD CT</b>	Adds the count to database	Press the <b>ADD CT</b> key to add the count to the database.
<b>SUB CT</b>	Subtracts count from database	Press the <b>SUB CT</b> key to subtract the scale count from the database.
<b>BASE</b>	Switches active base	Prompts to switch to selected base.
<b>SAVE TL</b>	Saves a transaction record	Press the <b>SAVE TL</b> key to enter a Transaction Log record.

<b>SET PTS</b>	Displays set point registers	Press the <b>SET PTS</b> key to display the sets point registers.
<b>LOW</b>	Enters number in low register	Enter the low limit and press the <b>LOW</b> Key.
<b>TARGET</b>	Enters number into the target	Enter the target limit and press the <b>TARGET</b> key.
<b>HIGH</b>	Enters number in high register	Enter the high limit and press the <b>HIGH</b> Key.
<b>X UNIT</b>	Enters beginning # in sequence	Enter the beginning # of the series and press the <b>X UNIT</b> key.
<b>Y UNIT</b>	Enters ending # in a sequence	Enter the ending # of the series and press the <b>Y UNIT</b> key.
<b>UNITS</b>	Switches units for active base	Prompts to switch to selected weighing unit.
<b>LOOP</b>	Starts a repeat loop	No prompt, automatic.
<b>REPEAT</b>	Marks the end of repeat steps	Press <b>REPEAT</b> to repeat last operation or sequence or press <b>ENDREPT</b> to continue.
<b>SKIP</b>	Continue after target stability	Press <b>SKIP</b> to skip over stability check
<b>DISPLAY</b>	Displays data in register	Press <b>END DPY</b> to continue.
<b>EXIT</b>	Exits macro	Press the <b>EXIT</b> key to end the Macro.
<b>TOPLINE</b>	Displays data in topline	Press <b>TOPLINE</b> key to display.
<b>EXECUTE</b>	Allows the scale to send commands to itself	
<b>IF</b>	Conditional Jump	
<b>JUMP</b>	Unconditional Jump	Press <b>JUMP</b> to go to new macro location

## Notes on Specific Steps

### Macro Step ID

If the ID step is selected when programming a macro, the following menu is displayed:

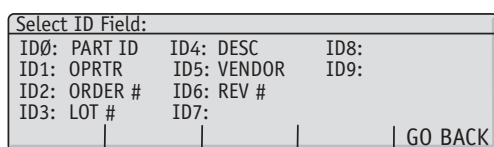

Using the numeric keypad, select the field to prompt for ID entry.



### Macro Step **PRINT**

If the print step is selected when programming a macro, the following menu is displayed:

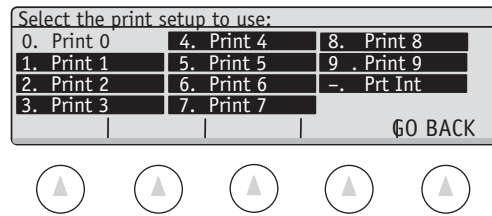

Using the numeric keypad, select the desired Print Register for printing.

### Macro Step **BASE**

If the base step is selected when programming a macro, the following menu is displayed:

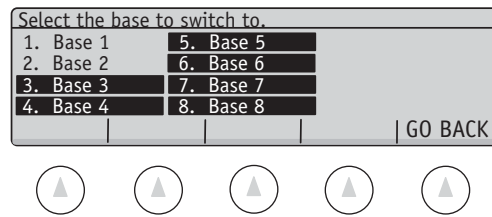

Using the numeric keypad, select the Base# to switch to:

### Macro Step **UNITS**

If the UNITS step is selected when programming a macro, the following menu is displayed.

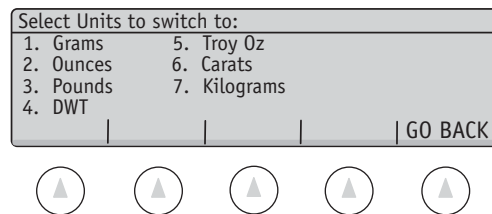

Using the numeric keypad, select the desired unit of measure.

### Macro Step **SKIP**

When this step is executed, the scale pauses execution. When the weight on the platter is stable and between the low and high setpoints, the next step is executed with no user input. If the user presses the **SKIP** key, the next few steps are skipped over (the number of steps is specified during programming). This function may be used to ensure that a checkweigh specification is met before printing labels or storing a transaction.

*Note: The default behavior of the skip step can be changed in the ALARMS setup menu. e.g. The step can be made to advance automatically whenever the weight is below the low setpoint.*

### Macro Step **LOOP** and **REPEAT**

Repeat loops are used when a bunch of steps are run repeatedly but the number of repeats is not known at programming time. Insert the LOOP step at the beginning of the loop and the REPEAT step at the end. When in the middle of a repeat loop, the right hand key changes function to ENDREPT which moves to the macro execution to just after the REPEAT step.

### Macro Step **DISPLAY**

If the **DISPLAY** step is selected when programming a macro, the following menu is displayed:

Select item to display by numeric entry:	
1. ID	4. Acc Weight
2. APW	5. Gross
3. Tare	7. Net
4. Acc Count	8. Count
GO BACK   EXIT	

▲   ▲   ▲   ▲   ▲

Using the numeric keypad, select the field to display.

### Macro Step **TOPLINE**

If the **TOPLINE** step is selected when programming a macro, the following menu is displayed:

Select item to display on top line:	
1. Off	4. ID 0
2. Alarms	5. Tare
3. Set Points	6. Counters
4. Accumulator	
GO BACK	

▲   ▲   ▲   ▲   ▲

Using the numeric keypad, select the desired data to be displayed.

### Macro Step **EXECUTE**

When an **EXECUTE** step is run, the prompt is moved to the 'IN' port receive buffer and processed as if it were an incoming command from a computer or bar code scanner. Either the older style commands or the newer SDL commands may be executed.

It is important to remember all SDL commands must be terminated with a character. This can be accomplished using SuperTalk with a line such as:

```
\step = EXECUTE, "SAMP SIZE = 10, 25, 100, 500<CR>"
```

More than one command can be executed in succession; the string "Z/ETHAN \$R1P"; for example would zero the scale, put "Ethan" into ID2, and then print register 1.

### Macro Step **JUMP**

The **JUMP** Step will cause the macro JUMP a number of steps either forward or backward. If the jump step is programmed to skip 1 step, the next step will not be run but the following step will be run. A jump of -1 will cause the previous step to run.

### Macro Step **IF**

The **IF** step adds conditional jumps to the prompting macros language. Each IF step is comprised of two elements: the conditional expression and the jump value. The conditional expression is written into the prompt during macro programming time. The expression is evaluated when the step is executed, and evaluates to either True or False. If the statement is True, the next macro step is executed. If the statement is False, the jump is taken. The number of steps jumped is designated at macro programming time.

The conditional statement is comprised of three elements: Operand1, Operator, Operand2. An example would be "Tare < 55.3". Note that the parser is fairly forgiving: the three elements may be strung together (such as "NetRegister >= 55.3") or separated by spaces (" NetRegister >= 55.3 "). Also, upper or lower case letters can be used interchangeably (except in string literals).

There are six types of operators:

<	Less than
<=	Less than or equal to
= (or the C-style ==)	Equal to
>=	Greater than or equal to
>	Greater than
!=	Not equal to

Any operator may be used with any Operand. For instance, it is perfectly legal to use the > operator on strings: in this case, ASCII ordering is used (ASCII ordering mostly follows alphabetical, with the exception that upper case characters are always greater than lower case characters).

There are two types of operands: variable and literal. Variable operands are retrieved their value from the scale when the step is executed. Literal operands are specified when the macro is programmed. There are basically two types of literal operands: numeric and string. Numeric operands can either be integer (such as 44) or floating point (such as 33.44 or 5.432E-6). All weights are assumed to be in grams units. String literals must be encapsulated by single quotation marks.

Variable operands must be selected from a the list of available keywords:

ID0  
ID1  
ID2  
ID3  
ID4  
ID5  
ID6  
ID7  
ID8  
ID9  
WEIGHT  
NETWEIGHT  
GROSSWEIGHT  
STABILITY (UNSTABLE STABLE VERY\_STABLE OVERLOAD UNDERLOAD)  
ACCUMCT  
ACCUMWT  
APW  
TARE  
UNITS (PIECE PIECES GRAM GRAMS OZ OZS LB LBS  
WT DWTS TROYOZ TROYOZS CARAT CARATS KG KGS GRAIN GRAINS)  
XCOUNTER  
LOW\_SP  
TARGET\_SP  
HIGH\_SP  
BASE  
COUNT

Note that two of the variables have keyword values associated with them. In both cases, the list of keywords represent an integer value (for example, Stable is 3, Very\_Stable is 4; this can be useful, ("Stability > 3" will be true whenever the scale is either stable or very stable).

The IF processor will perform some simple casting of variables. Casting is taking a variable of one type and changing it into another. For instance, the statement "Tare = ID0" doesn't make sense at first. The Tare register is a number, but the ID0 register is a string of characters. The processor takes the type of Operand 1, and changes the type of the second operand to match it. In the above example, the contents of ID0 will be made into a number (if the contents are numeric).

If there is an error detected in the conditional expression, the True branch (the next macro step) is executed. It is up to the programmer to check that the If statement is correctly executed by trying it out under several conditions and making certain that the correct behavior is exhibited.

Some SDL examples of valid IF steps:

```
\STEP = IF, "TARE != 0",2
```

```
\STEP = IF, "BASE < 4",1
```

```
\STEP = IF, "AccumWt >= 100",10
```



## Supervisor Setup Menu: Soft Key SETUP SECURITY

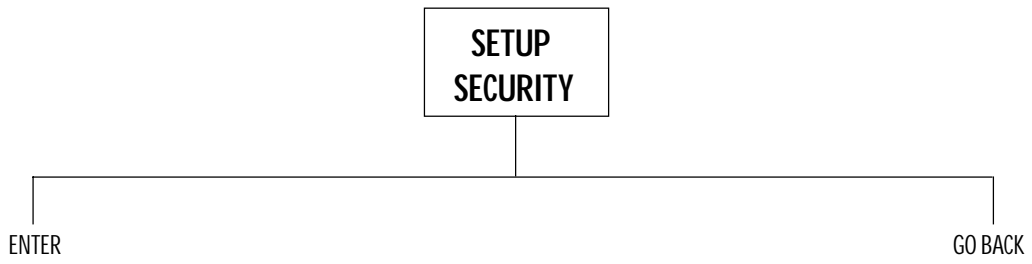

## SOFT KEY

# SETUP SECURITY

## Setting Supervisor Password Protection

This setup allows the set up of password protection for the Supervisor Setup menu.

To access the SETUP SECURITY menu, either follow the menu tree or press the keys in the order listed below:

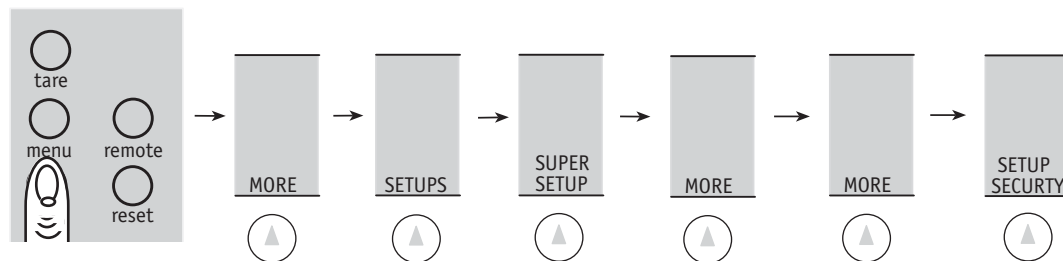

A password up to 10 characters in length can be typed in using the alphanumeric keypad (**abc** key) followed by the **ENTER** soft key.

ex: Type **XYZ 123** followed by **ENTER**

If the **ENTER** soft key is pressed without entering any characters, password protection is canceled.

Note: Password is case sensitive. If you lose your password, please contact Setra for a temporary password.

## Supervisor Setup Menu: Soft Key BEEPER CONTROL

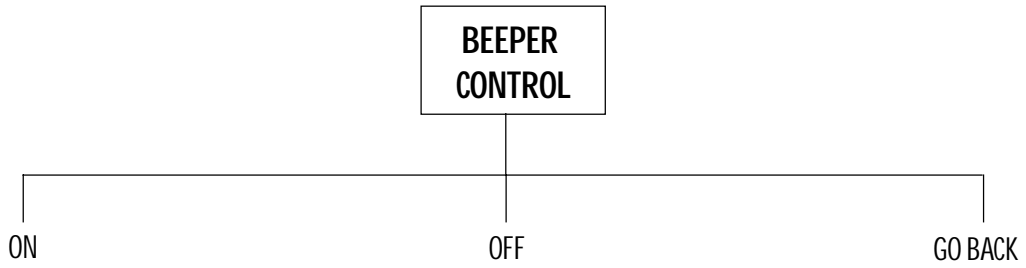



## SOFT KEY:

# BEEPER CONTROL

## Setting the Beeper to ON and OFF

To access the Beeper Control menu, either follow the menu tree or press the keys in the order listed below:

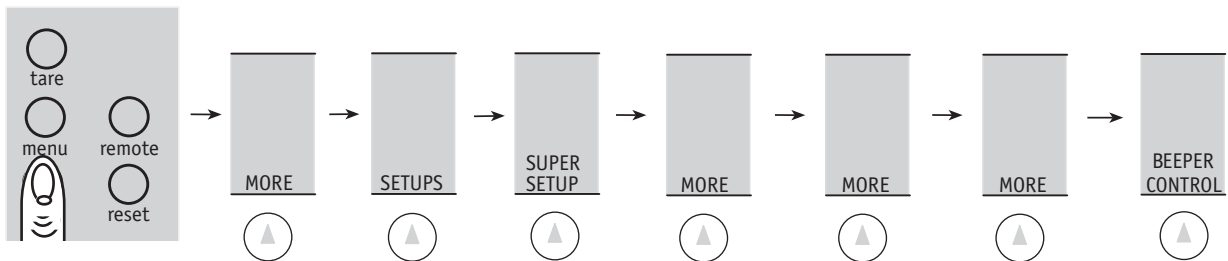

The following menu appears:

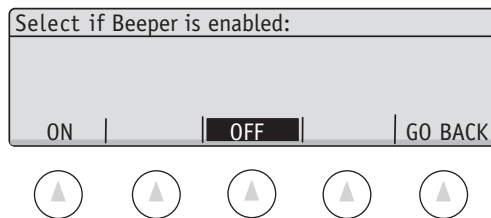

Select the **ON** soft key to enable the beeper and the **OFF** to disable the beeper.



## Bases Setup

## Bases Setup Menu: Soft Key CALIB

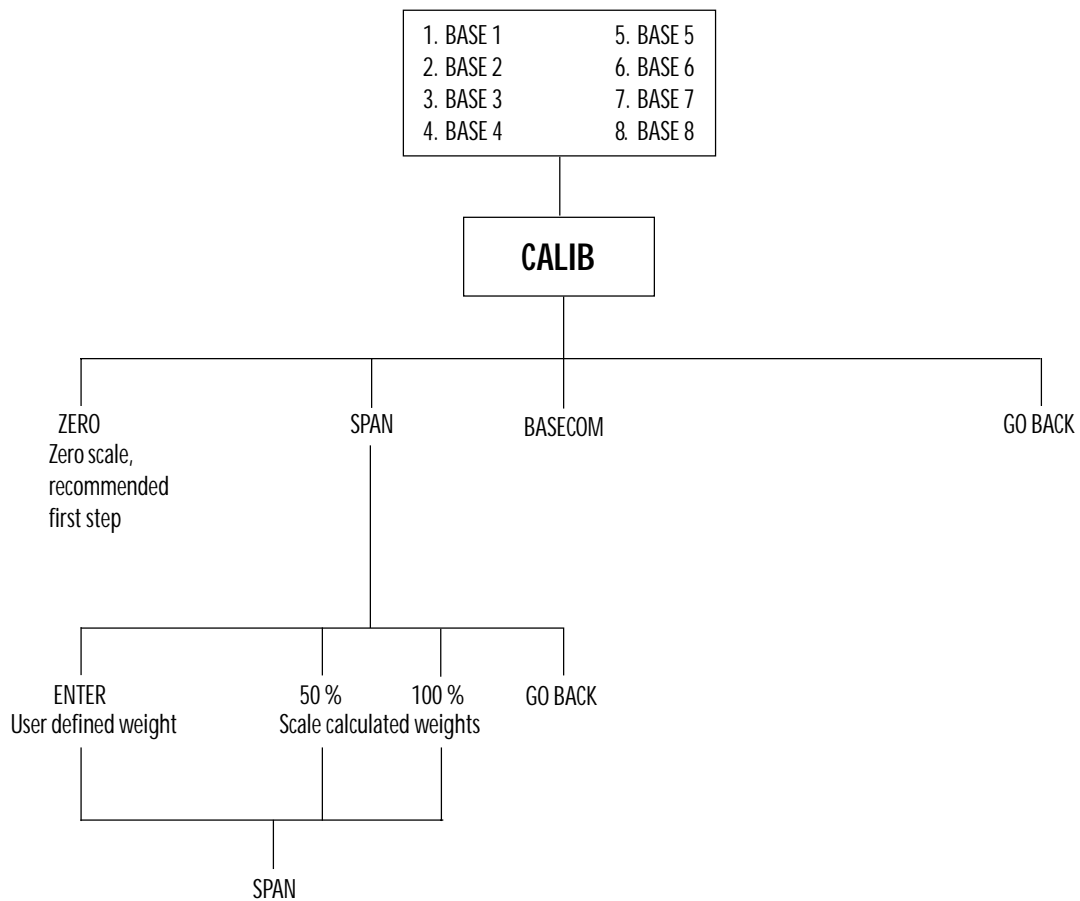

# Soft Key: **CALIB**

## Calibration

There are two types of calibration available. The most common type of calibration is referred to as a span calibration which is a single point readjustment of the calibration curve to a known weight value. The scale MUST be span calibrated when first installed to compensate for gravity differences between the point of manufacture and the point of installation. The second type of calibration is called a linearity adjustment. Multiple weight values are assigned to the calibration curve using several calibration weights.

The scale can be span calibrated as often as desired. A linearity calibration should only be necessary if the scale is out of tolerance (non-linear) after a span calibration has been performed. Frequency of calibration is dependent on many factors such as use of the scale, changes in the environment surrounding the scale and accuracy goals. Consult your local scale dealer for a calibration schedule.

To access the CALIBRATION selection in the Bases Setup menu, follow the menu tree or press the keys in the order listed below:

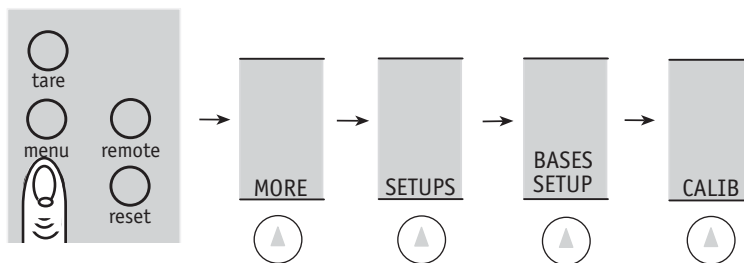

Press the **CALIB** soft key.

Before beginning either calibration procedure, the scale should always be level and in the weighing units of the calibration weight(s). Without anything on the pan, press the **ZERO** soft key and the message "Zero Base Process Activated" should appear on the top line.

### SPAN Calibration

1. Press the **SPAN** soft key to enter the span calibration menu.

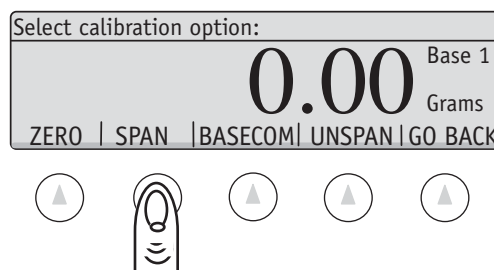

The soft keys will change to the following:

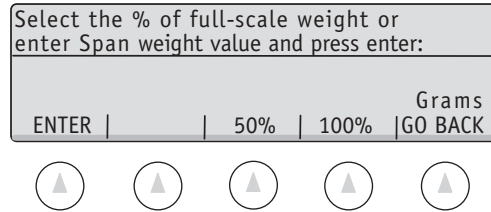

For the best results, the span weight should be as close as possible to the full-scale value or closest to the weight at which the scale is most often used.

2. Using the numeric keypad, enter the value of the span weight followed by the **ENTER** soft key or choose either 50% or 100% of scale capacity for spanning weight.
3. Place the required weight on the pan and press the **SPAN** soft key.
4. The scale will then perform a span calibration and display the weight value.
5. To unspan, press **UNSPAN** to return to the original factory span calibration.

### LINEARITY Calibration

Refer to your local factory authorized Setra scale dealer for an explanation of the Factory Menu that includes the linearity calibration procedure. The factory menu is accessed through the **BASECOM** soft key.

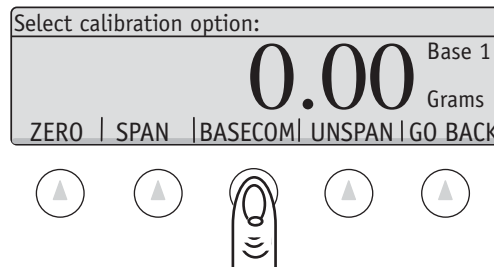



## Bases Setup Menu: Soft Key SPEED

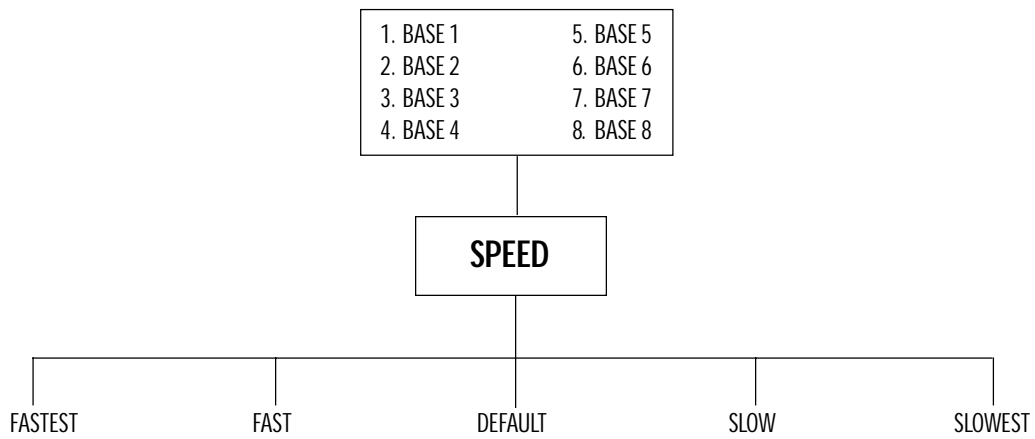



# Soft Key: **SPEED**

## Setting the Display Update Rate (Speed of Change for the Display)

Depending on the environment or application for the scale, it may be necessary to change the rate at which the display responds to changes on the platter. For some filling applications, it may be helpful to put the scale into a fast update rate to prevent overshooting a target. Conversely, for environments with draft or vibration, a slower update rate may provide greater stability. It may be necessary to make a trade-off between stability and update rate.

To access the **SPEED** setting in the Bases Setup menu, follow the menu tree or press the keys in the order

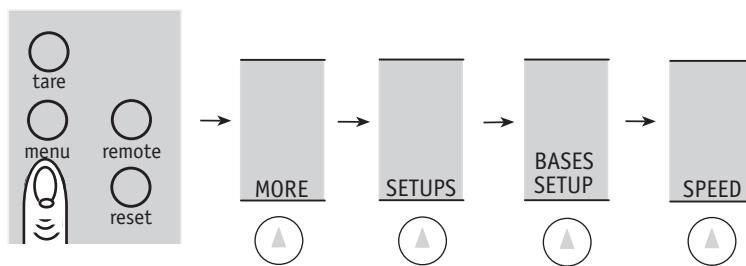

Press the **SPEED** soft key.

Simply choose the desired update rate by pressing the corresponding soft key.

## Bases Setup Menu: Soft Key ZERO

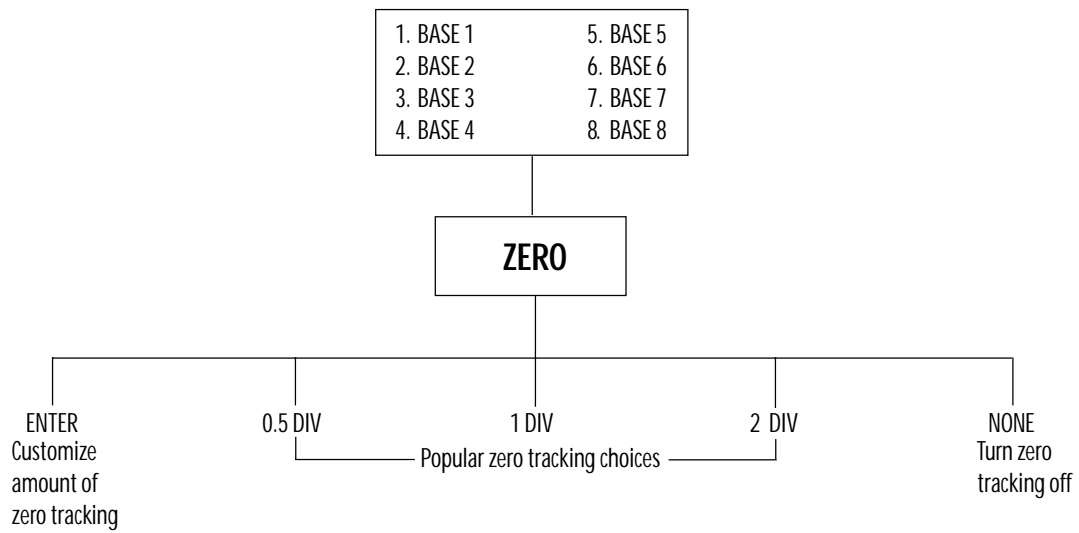

# Soft Key: **ZERO**

## Setting the Level of Zero Tracking

The scale is programmed with a level of zero tracking designed to help the scale maintain zero weight in a normal operating setting. Zero tracking works by rejecting very small changes in weight as “noise” and keeping the display on zero. For certain applications, such as monitoring slow flow rates, zero tracking can be turned off. On the other hand, in “bad” or “noisy” environments, zero tracking can be increased to help the scale maintain zero weight when nothing is added to it.

To access the ZERO setting in the Bases Setup menu, follow the menu tree or press the keys in the order listed below:

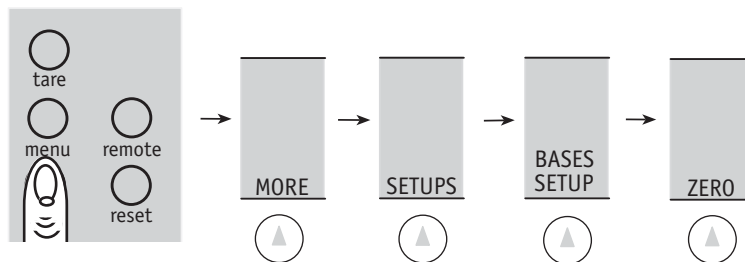

To enter a level of zero tracking, use the numeric keypad followed by the **ENTER** soft key or choose from the available options. A scale division is the smallest increment that the display is set to detect. The factory default is set for 1/2 division of zero tracking.

Note: A zero tracking window cannot be entered at greater than 100 displayed divisions.

## Bases Setup Menu: Soft Key RESOLUT

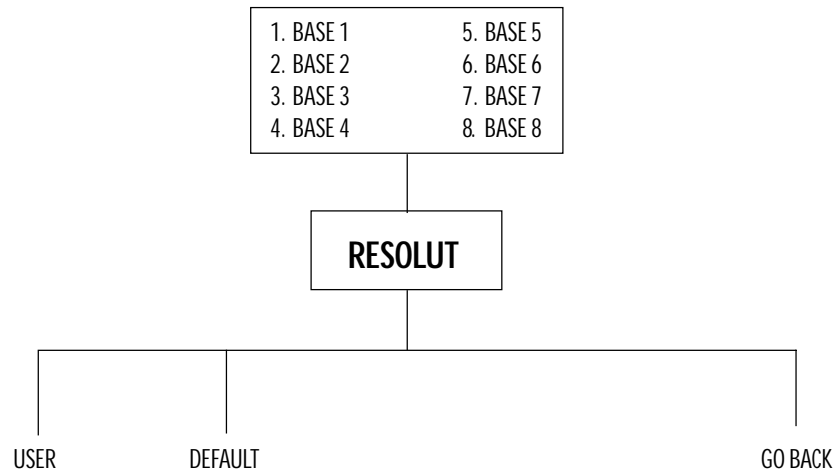

Soft Key:

# RESOLUT

## Setting the Resolution of the Displayed Weight

The high resolution Setra scale comes direct from the factory set at a readability that approximates the linearity characteristics of the scale. That is to say, after calibration, the displayed weight for any object placed into the center of the pan should not be off by more than the displayed increment from its true value. However, the scale is capable of detecting much smaller weight changes than those displayed as exemplified when counting very small pieces. The **RESOLUT** key can be used to increase displayed weighing resolution. Likewise, if the scale is not stable due to environmental factors such as draft or vibration, the resolution can be decreased to prevent display instability.

To access the RESOLUTION settings in the Bases Setup menu, follow the menu tree or press the keys in the order listed below:

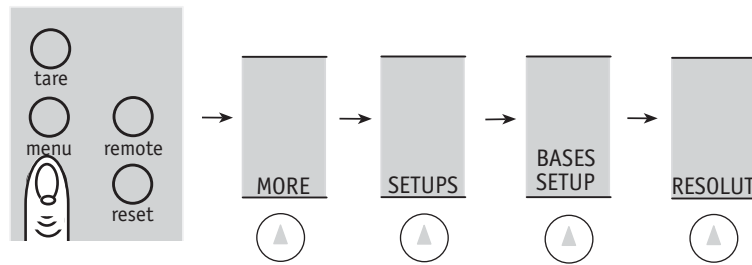

Press the **RESOLUT** soft key.

To program displayed increments, press the **USER** soft key. Using the numeric keypad, type in the last digit of resolution in grams followed by the **ENTER** soft key.

NOTE: Only resolutions up to a maximum of the sampling resolution, typically of 1 part in 1,000,000 will be accepted by the scale. All displayed resolutions in grams or any other unit of measure are rounded to the closest 1, 2, or 5 digit increment. Programmed resolutions that are greater than the factory default readability will be displayed with the last digit in reverse video as a notice to the user that the resolution is greater than the linearity characteristics of the scale.

To return to the scale's default resolution which closely matches the scale's linearity, press the **DEFAULT** soft key.

## Bases Setup Menu: Soft Key INFO

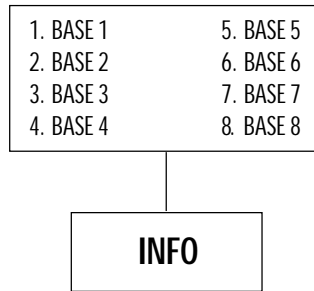

# Soft Key: **INFO**

## CHECKING BASE SOFTWARE REVISION AND SETTINGS

To access the INFO selection in the Bases Setup menu, follow the menu tree or press the keys in the order listed below.

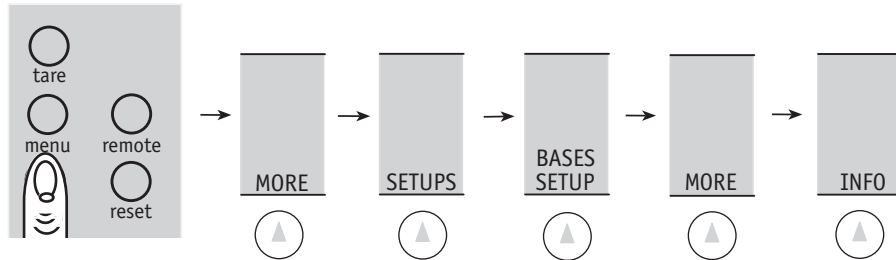

Press the **INFO** soft key.

The setup characteristics of either a Setra or a strain gauge load cell base can be recalled by pressing the **INFO** soft key. The following six characteristics will be displayed:

```
Base parameters for Base 1:  
Software Revision Version 1.XX  
Full Scale = 25000 g Sample Res. = 0.025  
Display Resolution = 0.3 g  
Zero Tracking Window = 0.500 g Speed = 3  
GO BACK
```



## Bases Menu: Soft Key NAME

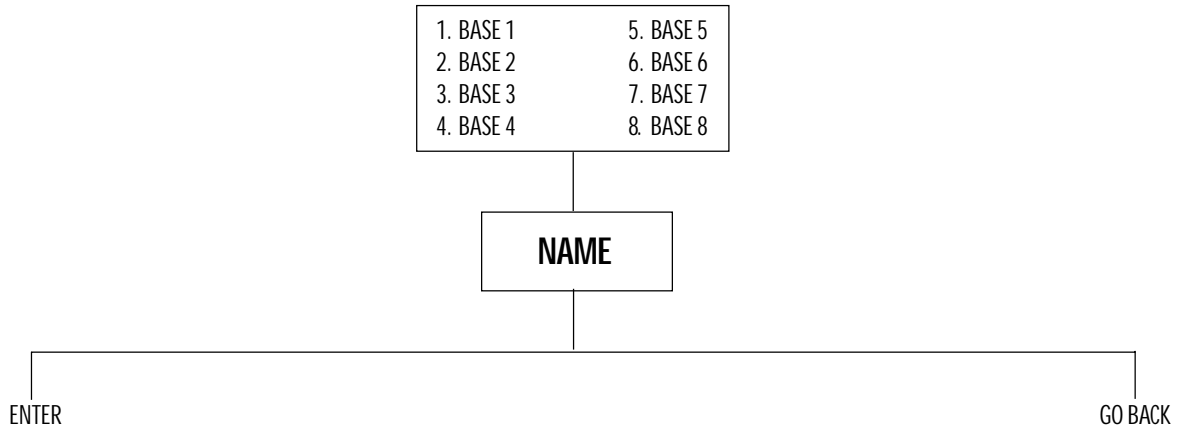



# Soft Key: NAME

## CHANGING THE NAME OF A BASE

To access the NAME selection in the Bases Setup menu, follow the menu tree or press the keys in the order listed below.

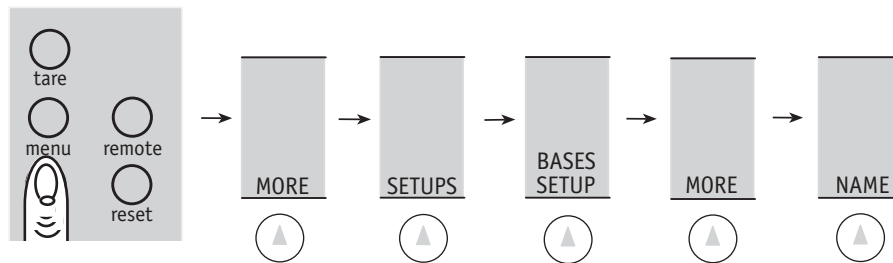

Press the **NAME** soft key.

The identification name of a base can be changed to help clarify its function. Examples of this are LOCAL and REMOTE for a dual scale system or SAMPLE, BULK, and PALLET for a three scale system. The only limitation when naming a base address is the six character description field.

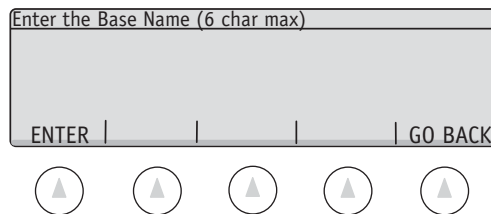

Using the alphanumeric keypad (**abc** key), type in the new name followed by the **ENTER** soft key.

## Bases Menu: Soft Key ADDRESS

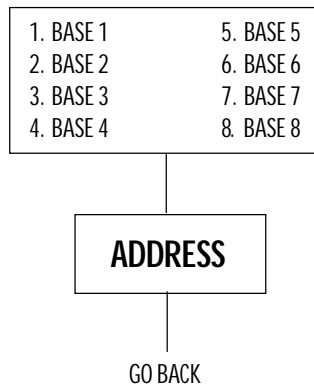

## Soft Key:

# ADDRESS

## Changing the Address of a Single Base

The Super II controller is capable of communicating with up to eight separate bases. Each base on the scale network must have a unique address from 1 to 8. As a default, all bases come from the factory set to address 1. Additionally, the Remote Scale Option circuit boards for strain gauge load cell remote bases come from the factory set to address 2. To access additional Setra or strain gauge load cell bases or to rename the current Setra or strain gauge load cell base, please follow the procedure below.

To access the ADDRESS changes in the Bases Setup menu, follow the menu tree or press the keys in the order listed below.

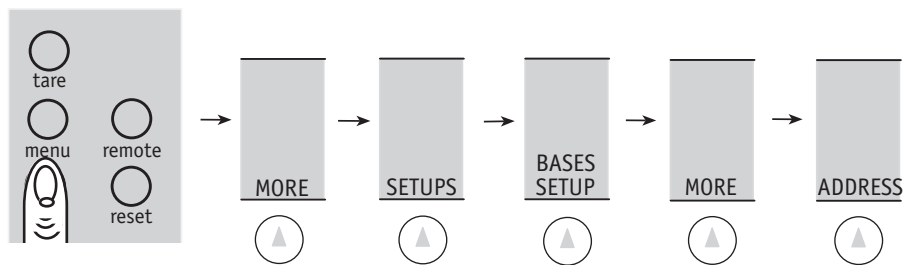

Press the **ADDRESS** soft key.

To add any additional bases beyond the standard Base 1 and Base 2 selections, or to reassign the address of existing bases, follow the procedure below:

1. Attach the Setra base to be reassigned directly to the controller with no other bases attached.
2. Apply power to the base.
3. After scale countdown, the base will appear as Base 1 (or another number if it has already been reassigned).
4. Access the Bases Setup menu by following the above procedure.
5. Press the **ADDRESS** soft key.
6. A menu will appear showing all eight possible base selections and the names associated with each base number.

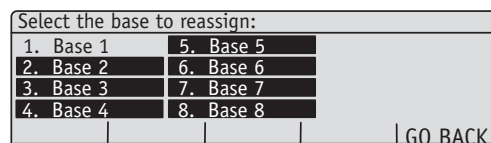

7. Using the numeric keypad, select the base address to reassign.
8. Using the numeric keypad, select the new address for the base.
9. Unplug the base with the new address changes and plug it into the base which will be connected to the controller (Base 1).

NOTE: Once a network is setup with not more than one base per address, you can switch base addresses without powering down the system.



## Bases Menu: Soft Key BASERST

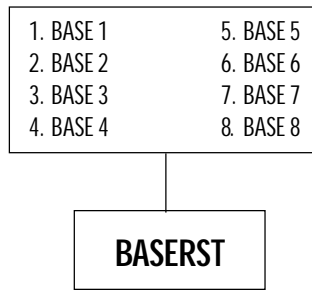

# Soft Key: **BASERST**

## RESETTING THE BASE

There may be times that the controller and the base network are out of sync. One example of this is the addition of a base without the powering down of the controller. Base reset will cause the controller to poll all addresses and search for bases.

To access the BASE RESET selection in the Bases Setup menu, follow the menu tree or press the keys in the order listed below:

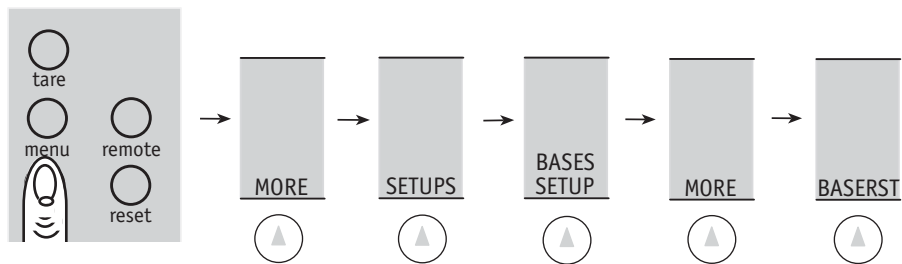

Press the **BASERST** soft key to display the following screen:

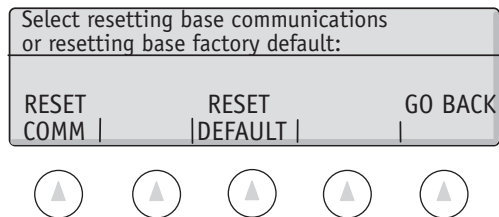

Press **RESET COMM** to begin the polling process to resynchronize the controller/base network. Press **RESET DEFAULT** to return the base to its factory defaults.





## Technical Setup

## Technical Setup Menu: Soft Key GREETNG

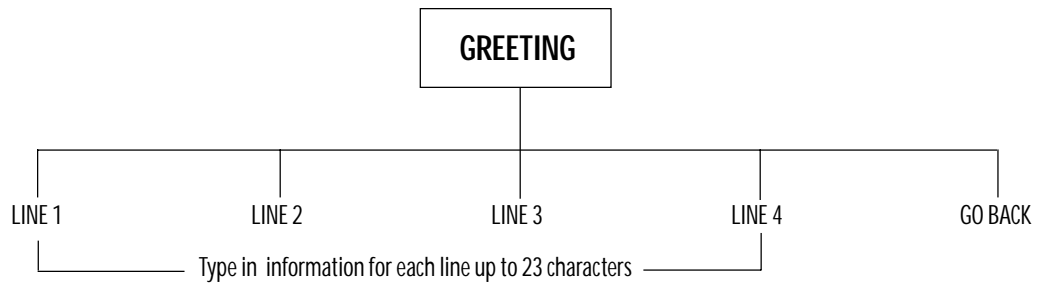

## Soft Key:

# GREETNG

## Setting the Power-Up Greeting

When power is first applied to the scale, a greeting message is displayed showing the time and date along with Setra's address and telephone number. This occurs during the 30 second countdown procedure while the scale performs a self-test. The greeting can be changed to a custom message. We recommend either a dealer's name and telephone number for service or the end user's name and address to denote property ownership.

To access the power-up greeting message, either follow the menu tree or press the keys in the order listed below:

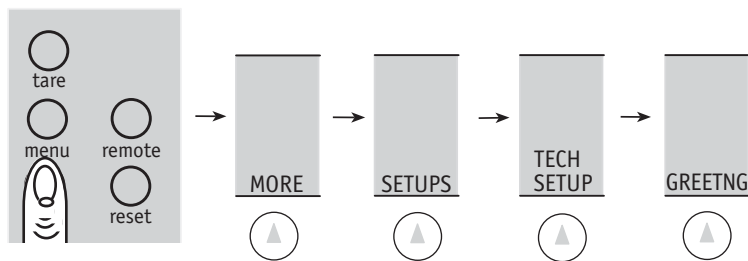

There are four lines of 23 characters available to set the desired greeting message.

The screenshot shows a text input field with the prompt "Type Greeting and select line to enter:". Below the input field, there are five selection options: "LINE 1", "LINE 2", "LINE 3", "LINE 4", and "GO BACK". Each option has a circular button with an upward-pointing arrow below it.

Using the alphanumeric keypad (**abc** key) or PC keyboard, type in the desired message for each line (up to 23 characters) and press the **LINE #** key to specify where the text should appear.

## Technical Setup Menu: Soft Key BACKLIT

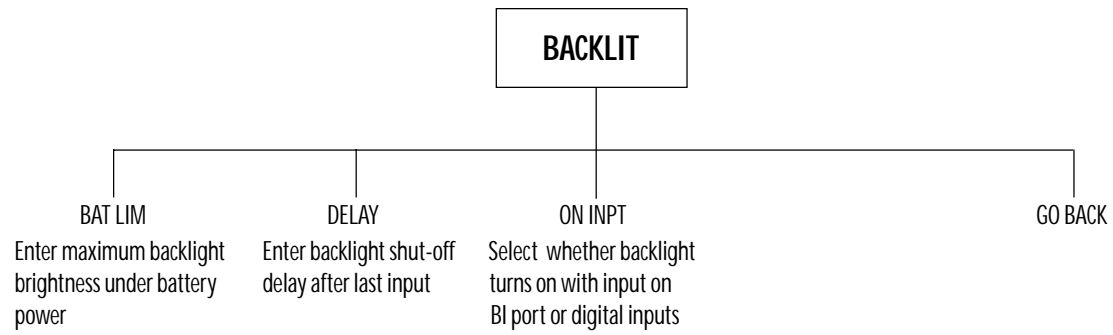

Soft Key:

# BACKLIT\*

## BACKLIGHTING OF THE DISPLAY

Adjustment of the backlight brightness can be done at any time from the front panel keys. Pressing and holding the **abc** key and then pressing the left arrow key will decrease the brightness of the display. Pressing and holding the **abc** key and then pressing the right arrow key will increase the brightness of the display.

The controller can detect whether the scale is running off a (12 volt) battery or a (16 volt) AC adapter. The scale can be set up to reduce the backlight brightness when running on batteries to save battery life. In addition, the backlight will shut off when powered by batteries if the scale is not in use. Both of these battery saving features are configurable.

To access backlighting battery power saving features, either follow the menu tree or press the keys in the order listed below:

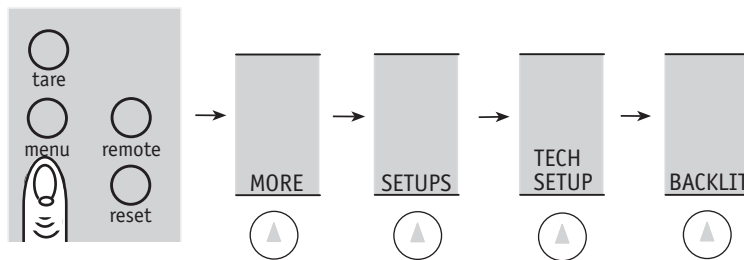

After pressing the **BACKLIT** soft key in the Technical Setups menu, the following screen will appear:

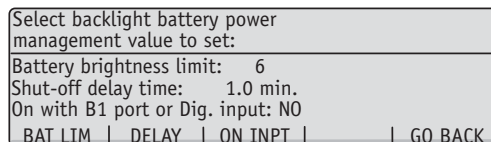

If the **BAT LIM** soft key is pressed, the following display appears:

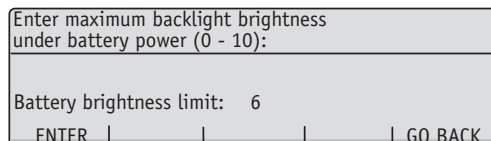

Brightness can be set to a whole number value between 0 (backlight off under battery power) to 10 (full backlight brightness available under battery power). The factory default setting for the battery limit is 6.

\* For scales with the backlight option.

Press the **DELAY** key:

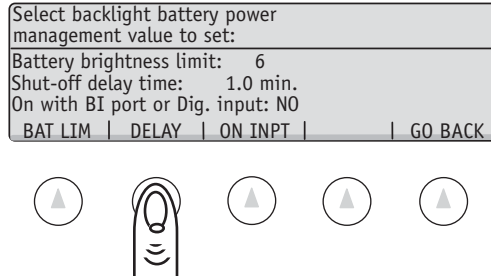

The following screen appears:

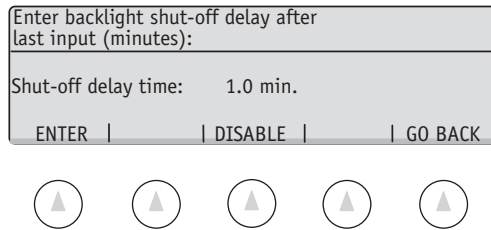

Using the numeric keypad, press the desired power saving delay followed by the **ENTER** soft key. When performing automated scale functions, such as computer communications through the BI port or control by process equipment through the digital inputs, the back light will remain off. This behavior can be changed using the ON INPT function.

Press the **ON INPT** soft key:

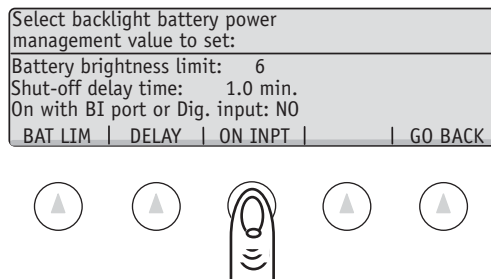

The following screen appears:

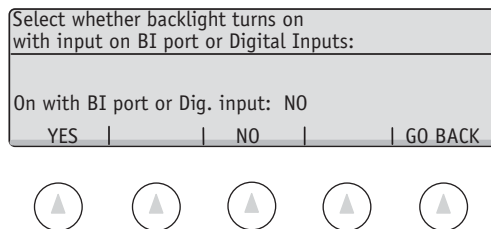

The supervisor can select automatic reactivation of the backlight if input is received on the Bi-Directional Serial Port or one of the Digital Input lines. The default is NO.



# Technical Setup Menu: Soft Key SETUP TRANSFR

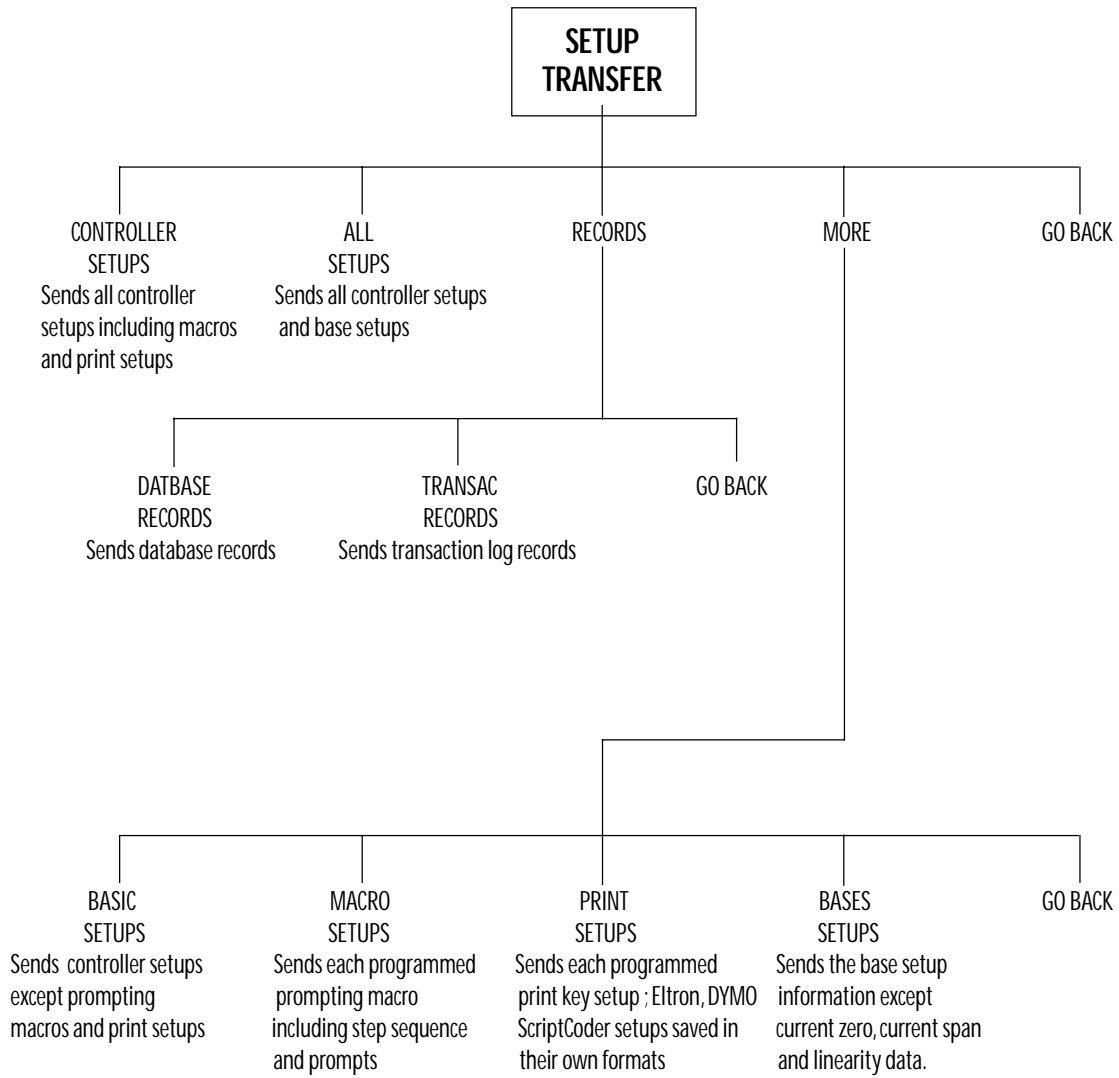



Soft Key:

# SETUP TRANSFR\*

## TRANSFERRING THE SCALE SETUPS TO A COMPUTER OR SCALE

The controller uses an interface language called the Setra Dialog Language (SDL). Using SDL, the setup information can be transferred to another scale or to a computer file in order to back up the scale setups. Through the SETUP TRANSFR menu, the entire scale setup, or a portion of the setups, can be sent out the BI port.

To access the SETUP TRANSFR menu, follow the menu tree or press the keys in the order listed below:

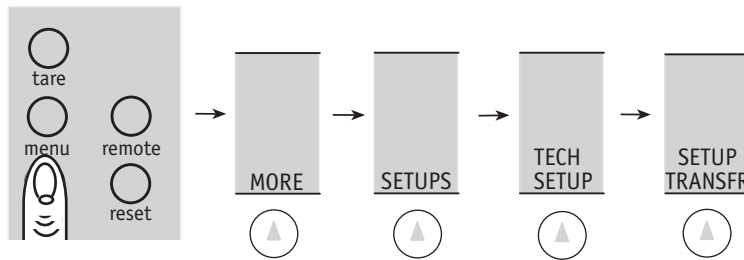

The following screen and soft keys appear:

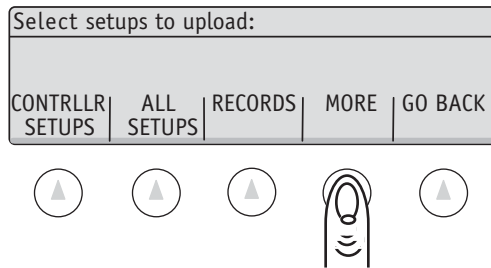

Pressing the **MORE** soft key will display the following additional choices:

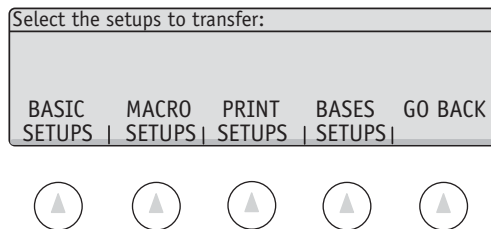

Press the **RECORDS** soft key:

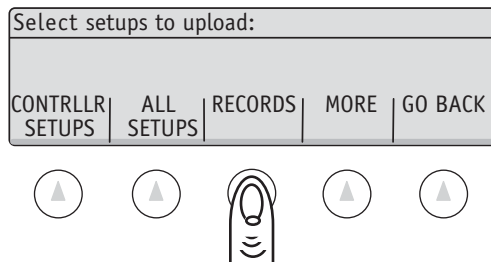

\* Available in Software Revisions 3.01 and higher.

The following additional choices will be displayed:

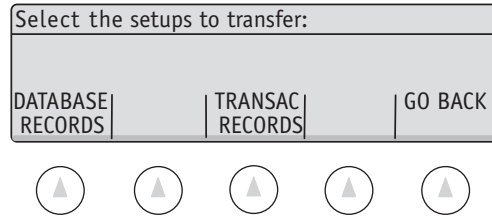

Press one of the transfer options shown on the previous page to transfer some portion of the setups:

- CNTRLLR SETUPS** Sends all the controller data including the prompting macros, print setups, and controller setups (see below). Does not transfer the bases setup, transaction log records or the database records.
- ALL SETUPS** Sends all the above CNTRLLR setups as well as the base setups.
- BASIC SETUPS** Sends the Controller setups described in this manual except the prompting macros and the print setups.
- MACRO SETUPS** Sends each prompting macro that has been programmed. Eltron, DYMO, and ScriptCoder setups are saved in their own format.
- BASE SETUPS** Sends the base setup information. The following items are not base setup information and cannot be read from the base: the current zero, the current span, and the linearity data.
- DATABASE RECORDS** Sends the database records.
- TRANSAC RECORDS** Sends the transaction log records.

The PC Based program "SuperTalk" is recommended for transferring to a computer. Contact your Setra dealer to obtain a copy.



# Technical Setup Menu: Soft Key RESET

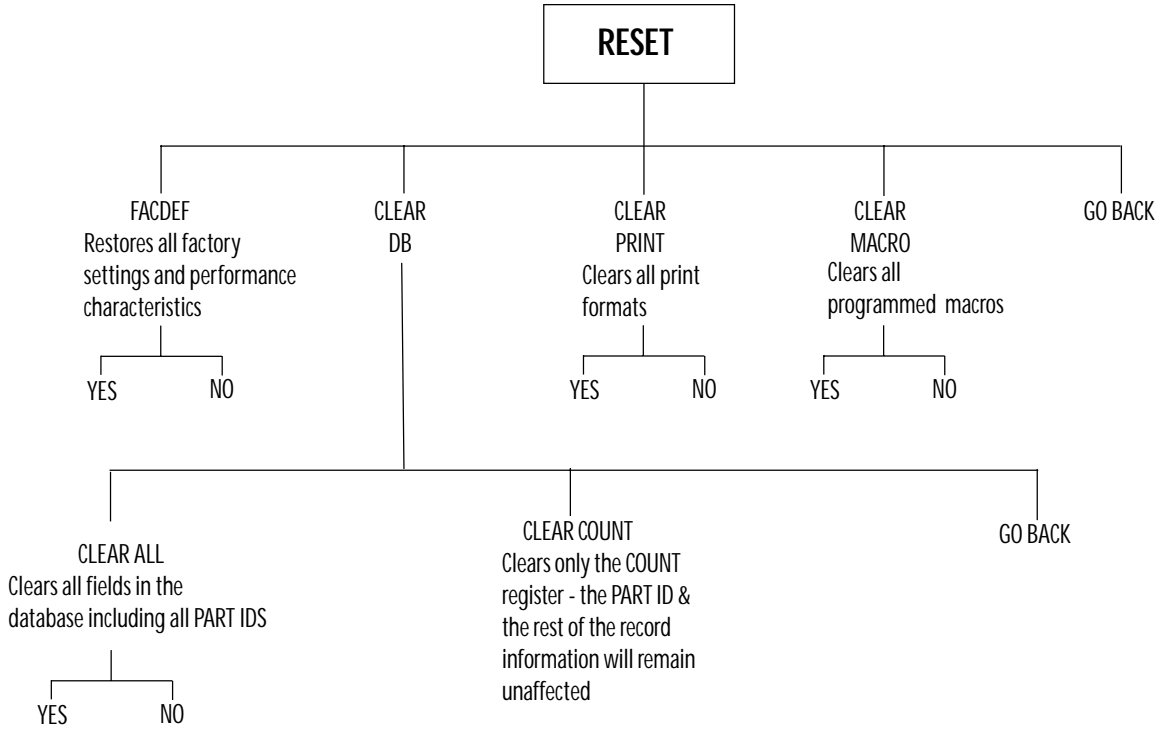

# Soft Key: **RESET**

## Resetting the Factory Defaults and Clearing the Database, Print Registers, and Macros

Due to the programming flexibility of the scale, it may sometimes be desirable to go back to the factory defaults as a launching point for new customization. To view the scale's setups, send them to a computer or printer by using the **CONTROLLER SETUPS** selection in the **SETUP TRANSFR** soft key section of this manual. Separately, the scale's Database, Print Registers, and Macros can each be cleared or reset for new programming.

To access the **RESET** menu, follow the menu tree or press the keys in the order listed below:

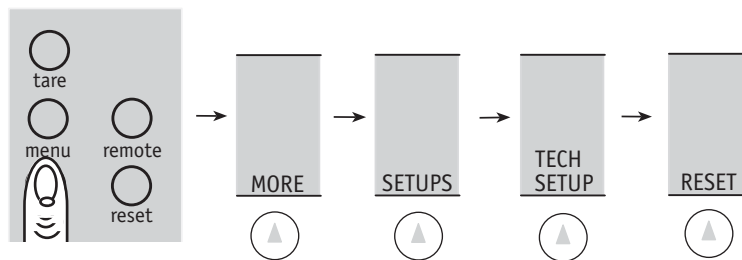

There are four **RESET** choices available:

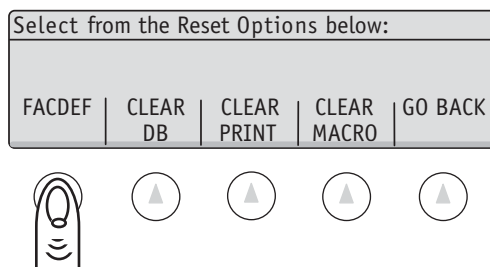

**FACDEF** will restore all scale performance parameters and RS232 setups to the factory default settings.

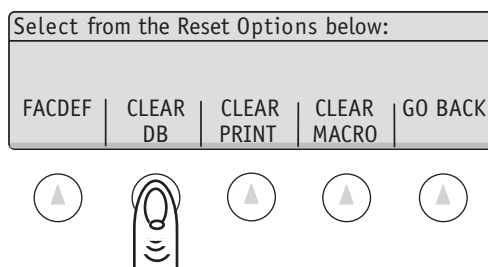

**CLEAR DB** will bring up the following options:

Select from the database clearing options listed below:		
CLEAR ALL	CLEAR COUNT	GO BACK



**CLEAR ALL** will clear all database fields including the PART ID (ID0) and leave the database completely empty. The transaction log is not affected.

Select from the database clearing options listed below:		
CLEAR ALL	CLEAR COUNT	GO BACK

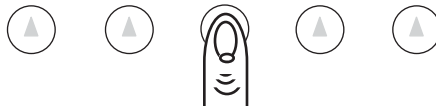

**CLEAR COUNT** will reset only the accumulated count register back to zero for each record in the database to allow the same pieces to be recounted. The transaction log is not affected.

Select Reset Option:				
FACDEF	CLEAR DB	CLEAR PRINT	CLEAR MACRO	GO BACK



**CLEAR PRINT** will clear all 10 print registers and leave them completely empty.

**CLEAR MACRO** will clear all 10 prompting Macro registers and leave them completely empty.

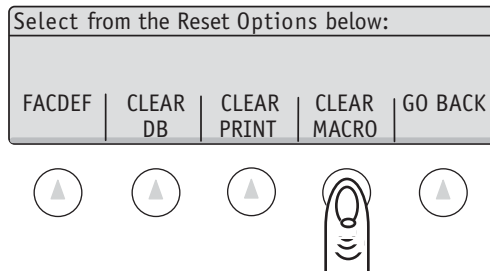

## Technical Setup Menu: Soft Key AUTO SWITCH

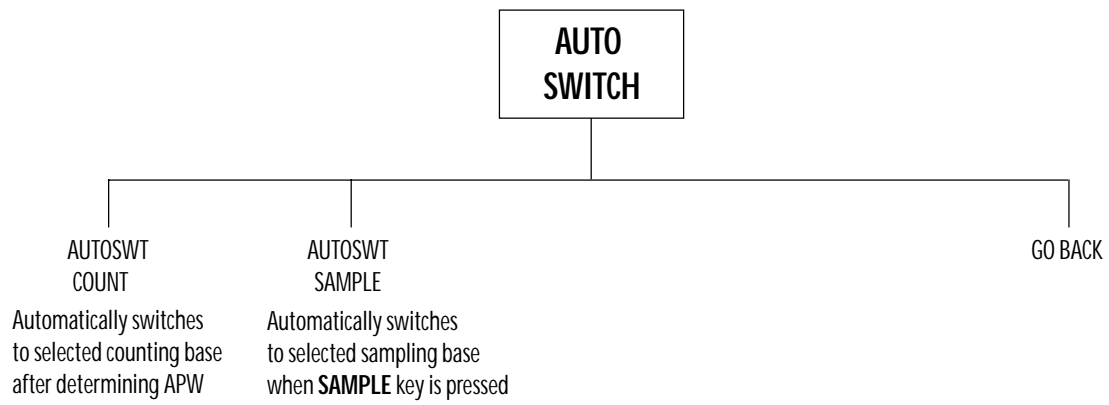



## SOFT KEY:

# AUTO SWITCH

## Selecting Special Remote Scale and Multiple Base Switching Options

This setup allows selection of special features for use in a two or more base scale system. There are two setup options available that are listed below.

To access the AUTO SWITCH menu, either follow the menu tree or press the keys in the order listed below:

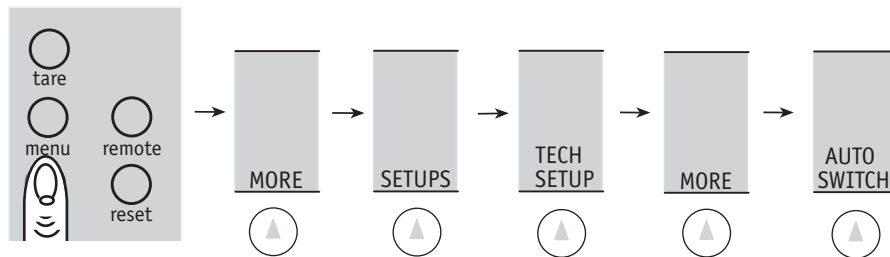

Make a selection from the following two choices:

**AUTOSWT COUNT:** When this feature is active, the controller will automatically switch to a specified base after an APW is determined.

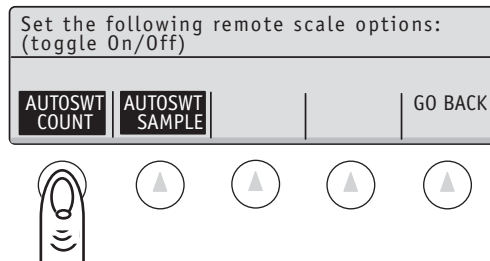

**AUTOSWT SAMPLE:** When this feature is active, the controller will automatically switch to a specified base whenever the SAMPLE key is pressed.

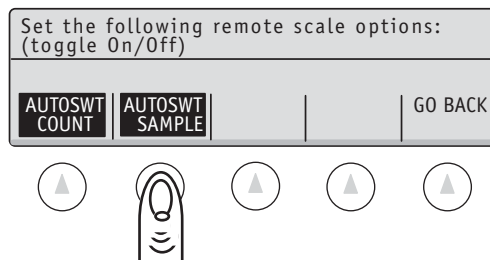

Note: Please refer to the BASES SETUP menu if necessary to rename the bases to LOCAL and REMOTE or SAMPLE and BULK or any other name, up to six characters.

# Technical Setup Menu: Soft Key ALARMS

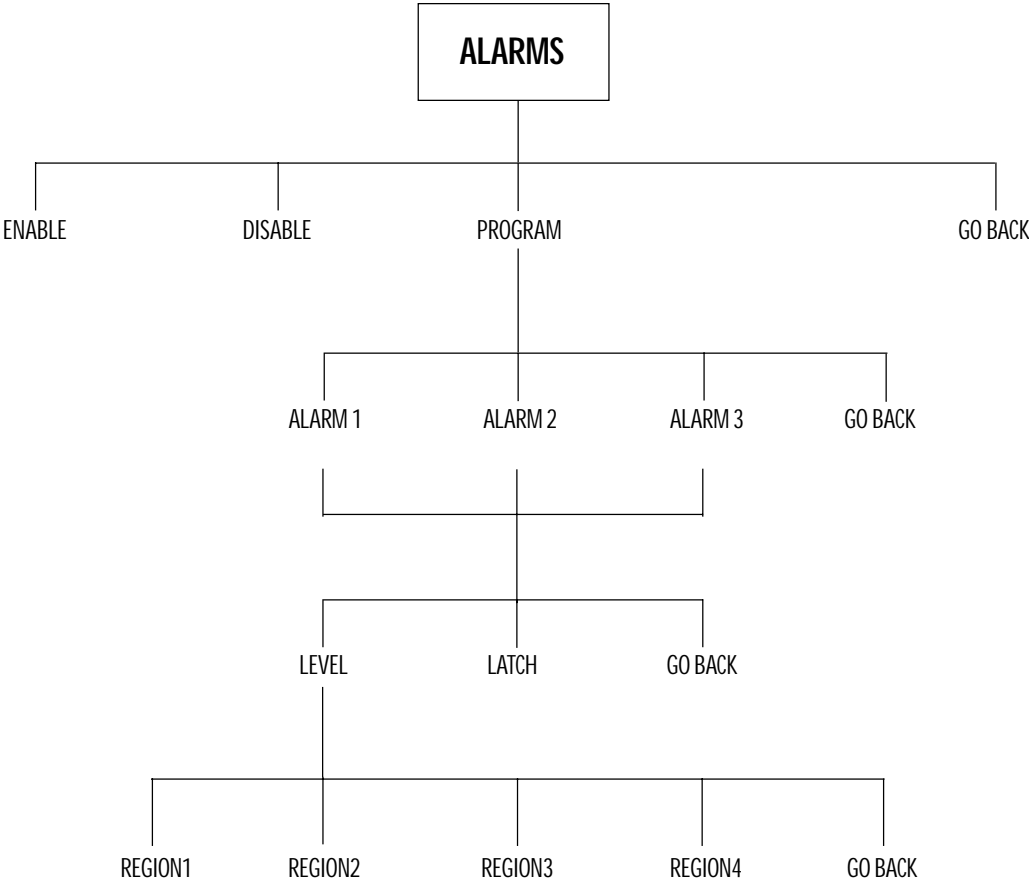

# Soft Key: **ALARMS**

## Setting Up the Alarm Outputs

The controller has three digital alarm outputs that can be used to control an external system. The alarm output pins are located in the OUT port. The state of the alarm is based on the weight of the scale relative to the set points (see the SETPOINTS soft key in the USER'S MANUAL). The alarm pins are held at either 0 volts (LO) or 5 volts (HI).

There are three set points that the operator can program: Low, Target and High. The set points can be programmed to any weight as long as the Low set point is lower than the Target set point and that, in turn, is lower than the High set point. The three set points create four weight regions. Region 1 covers all weights lower than the Low set point. Region 2 is between the Low and Target set points. Region 3 is between the Target and the High set points. Region 4 covers all weights greater than the High set point. Each alarm can be programmed to be either LO or HI in each of the four regions.

In addition to the alarm outputs, the SKIP macro step can be programmed using this menu. Normally, the SKIP step will automatically advance whenever the weight is stable and between the LO and HI setpoints. The range that will cause the SKIP step to automatically advance can be changed in a way similar to programming an alarm.

The alarm can be configured to be either latching or non-latching. When in the latching mode, once an alarm output has changed state, it will remain in the new state until a reset signal is received (the reset signal can be sent through the digital inputs, the keypad, or an SDL command).

When the alarms are programmed, the user menu selection SETPOINT changes to ALARMS. The functionality of the SETPOINT remains in the menu selection, but extra controls are added for operating the alarms. See the "User Manual" for further details.

To access the ALARMS menu, follow the menu tree or press the keys in the order listed below:

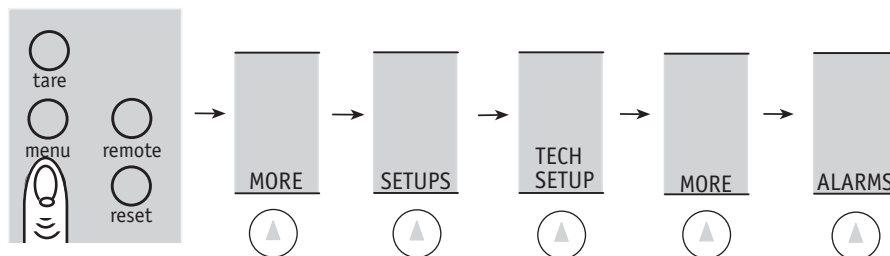

Choose from the options below or select an alarm to configure by selecting the alarm number on the numeric keypad.

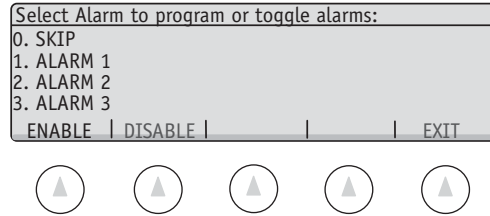

Turn the alarm system on or off using the **ENABLE** or **DISABLE** buttons. When the alarms are disabled, all the outputs are set to their zero weight states. When the alarms are enabled they follow the chart shown on the ALARM OUTPUTS screen where LO indicates that the alarm pin will be 0 volts relative to ground and HI indicates 5 volts. Thus, on the display shown below, when the weight is between the TARGET and HIGH set points, the output of the ALARM1 is HI.

To configure an alarm, select the alarm number using the numeric keypad and the following screen and soft keys are shown:

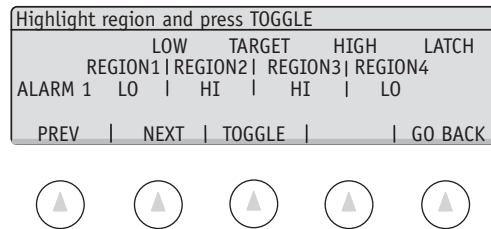

Press **PREV** and **NEXT** to highlight a particular region and **TOGGLE** to switch between HI and LO. As a short cut, you can press the region number on the numeric keypad to toggle a region and '5' for the LATCH. When a "lock" is displayed in the LATCH column, the alarm is latching. (See above description)



Technical Setup Menu: Soft Key DIG INP

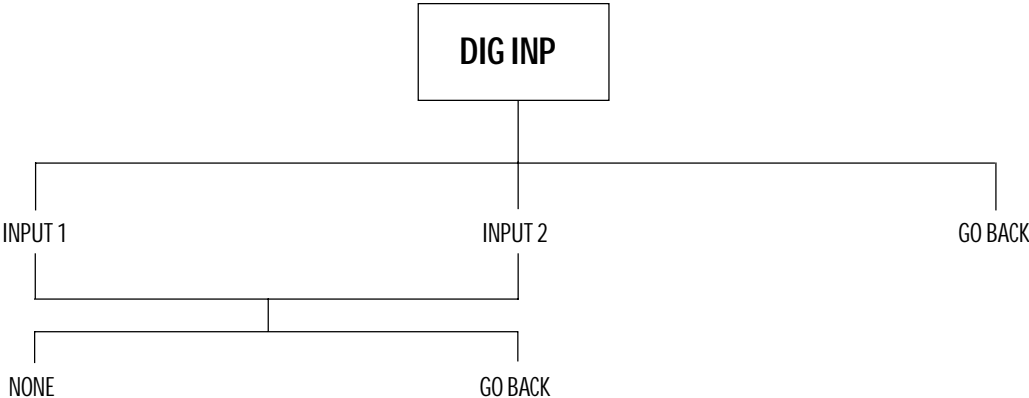

# Soft Key: DIG INP

## Setting the Digital Inputs

Digital Inputs allows an external system to signal the controller to perform an action. There are two digital input ports: Input 1 is located on pin 4 of the IN port and Input 2 is located on pin 5 of the IN port. The input port is triggered when the voltage on the ports goes from 0 volts (off) to 5 volts (on). When an input is triggered, the controller performs a preselected action. The list of actions that can be selected include zeroing, taring, printing, accumulating the weight or count, controlling the alarms, and controlling the prompting macros.

To setup the DIGITAL INPUTS either follow the menu tree or press the softkeys in the order below:

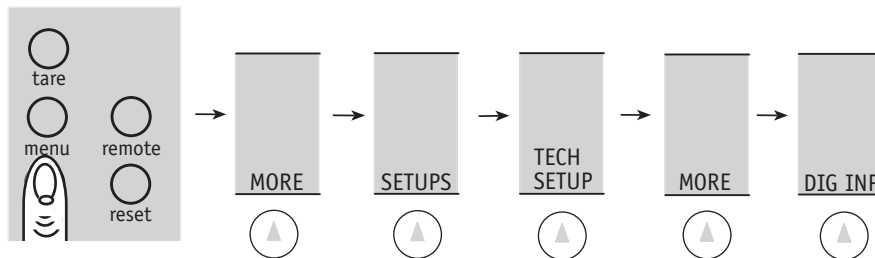

The following menu is displayed and the soft keys change to:

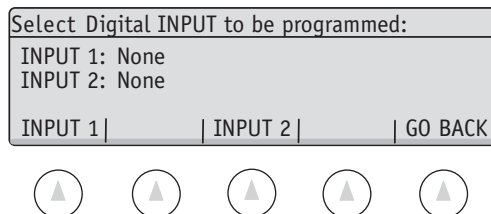

The screen shows the current function that the INPUT 1 and INPUT 2 digital ports are programmed to perform. Select the **INPUT 1** or the **INPUT 2** soft keys to program the input port function. Pressing the **INPUT 1** or **INPUT 2** soft key will make the following menu and soft keys appear:

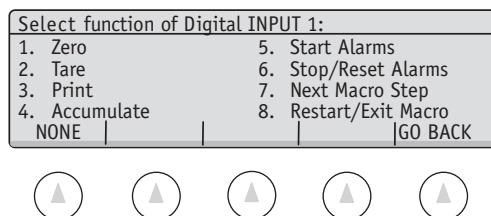

Using the numeric keypad, make your selection for the function of either INPUT 1 or INPUT 2.

## Technical Setup Menu: Soft Key SETUP SECURITY

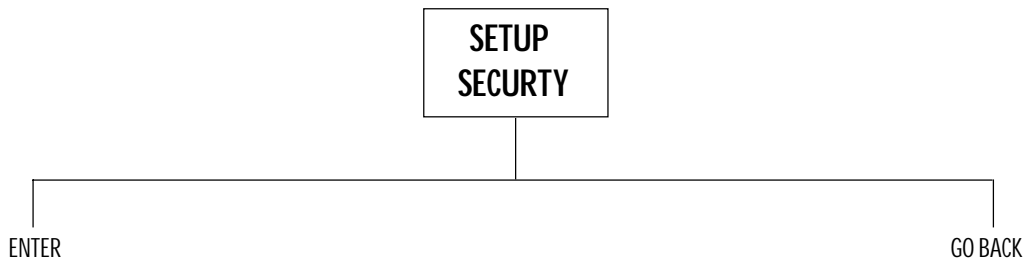



# SOFT KEY: SETUP SECURITY

## Entering Technical Setup and Bases Setup Password Protection

This setup allows the setup of password protection for the Technical Setup and Bases Setup menus.

To access the SETUP SECURITY menu, either follow the menu tree or press the keys in the order listed below:

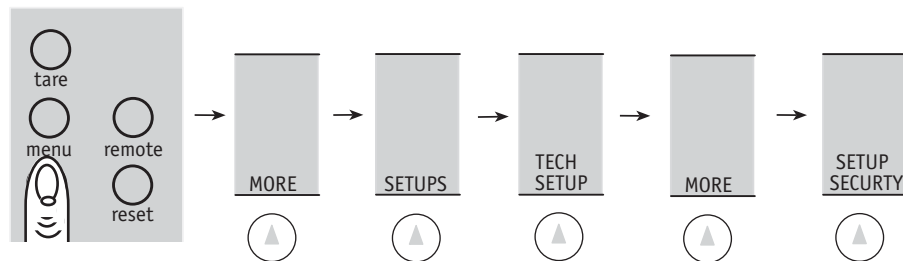

The following menu is displayed and the soft keys change to:

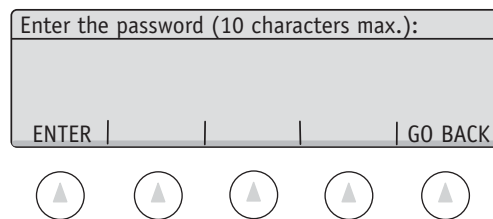

A password up to 10 characters in length can be typed in using the alphanumeric keypad (**abc** key) followed by the **ENTER** soft key.

ex: Type **XYZ 123** followed by **ENTER**

If the **ENTER** soft key is pressed without entering any characters, password protection is canceled.

Note: Password is case sensitive

If you lose your password, please contact Setra for a temporary password.

## Technical Setup Menu: Soft Key HYSTERS

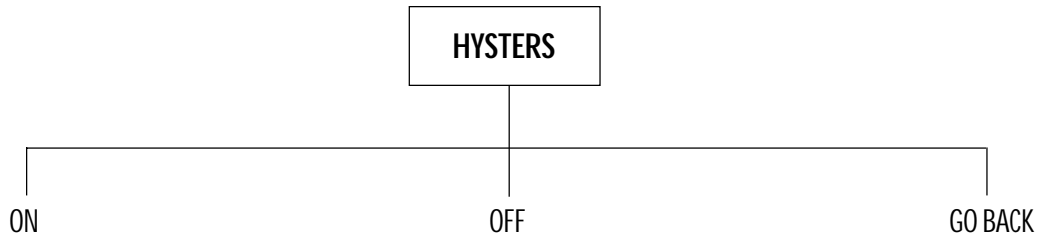

## Soft Key:

# HYSTERS

## Improving Display Stability

### DISPLAY HYSTERESIS

Display hysteresis refers to the function which prevents the apparent “jumpiness” of a display that is toggling between two weight readings. For example, if a weight is equal to 235.65 grams on a display set to be read by .1 grams, the display may have trouble settling between 235.6 and 235.7. Display hysteresis will prevent any changes to the display that are less than 1 displayed increment. Hysteresis should only be turned on if the environment is unstable but the user requires the readability and update rate of the current settings.

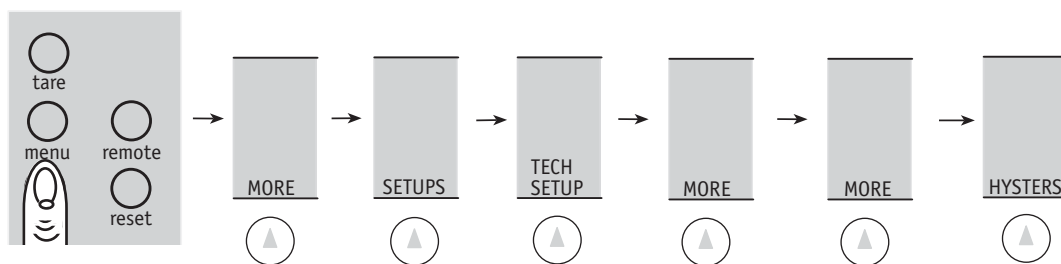

1. Access the HYSTERS setups menu by following the steps outlined above.
2. Press **ON** to activate display hysteresis.

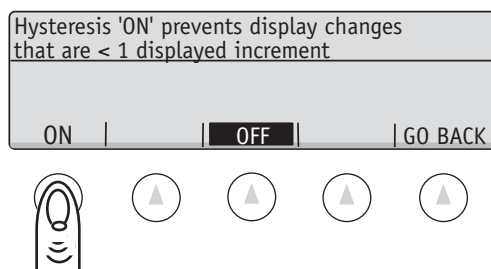

NOTE: Hysteresis is OFF by default.

## Technical Setup Menu: Soft Key APW QTY

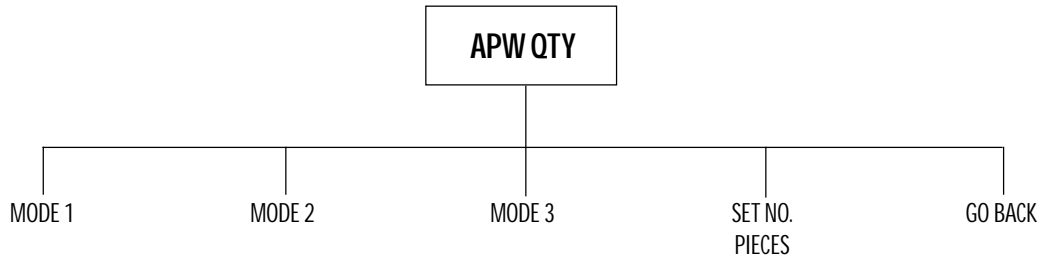

Soft Key:

# APW QTY

## Changing the APW Quantity Feature

The APW quantity feature is used to change the storage method of the APW. Normally, the APW, or Average Piece Weight, represents the average weight of a single piece. Using the APW Quantity feature, the APW can be made to represent the weight of a number of pieces. Thus, if the need is to count dozens of pieces, set the APW quantity to 12 and the APW displayed and printed will be the weight of a dozen pieces.

The APW mode sets the behavior of the scale when a new part is counted. The following APW quantity modes are available:

### Mode 1: APW Single Piece Mode

APWs are always entered and reported as the average piece weight of a single piece determined by dividing the number of pieces in a sample into the total sample weight.

### Mode 2: APW Quantity Mode

APWs are always entered and reported as the net weight of a pre-determined quantity of pieces. This quantity is set using the **SET NO./PIECES** soft key. For example, when using an APW Quantity of 1000, the scale will treat the entered APW value as the net weight of 1000 pieces and will use this value to determine the total count from the weight on the pan.

### Mode 3: APW Variable Quantity Mode

Similar to the APW Quantity Mode, this selection sets the scale's default entry and reporting of the APW to be based upon the net weight of a specific quantity, but allows the scale to receive APWs through the RS232 port (from bar codes or from a PC) that are defined using the net weight of a different number of pieces. The scale will temporarily use the net weight of a different number of pieces received through the RS232 port until the **RESET** key is pressed. For example, in this mode a scale set up for entry of APW 1000 will allow the use of APWs entered as the net weight of one piece if the APW is scanned from a bar code label. By pressing **RESET**, the scale will revert back to accepting keyboard entry of APW 1000.

To access the APW quantity setup, follow the menu tree or press the keys in the order listed below:

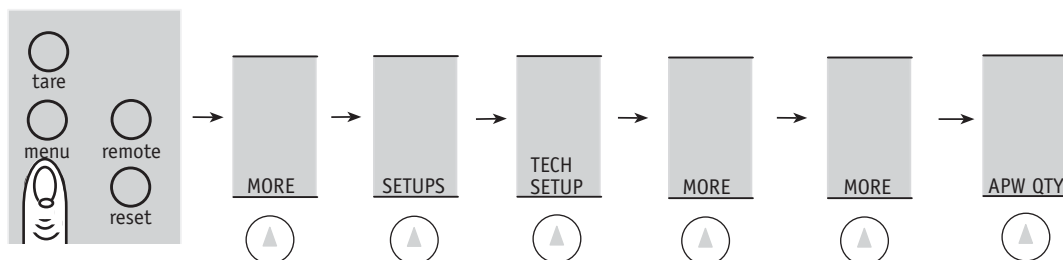

The following screen and soft keys will be displayed:

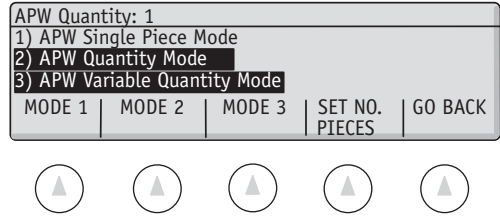

Select the APW quantity mode desired using the **MODE 1**, **MODE 2**, or **MODE 3** soft keys.

Press the **SET NO. PIECES** soft key to display the following screen and soft keys: Either select a predefined APW quantity from the soft keys or enter a custom APW quantity using the numeric keypad and press enter.

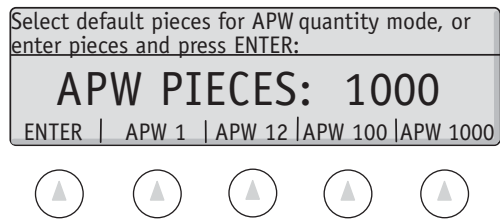

### RS232 Serial Port Communications

The Super II comes equipped with three RS232 ports. They are labelled **BI**, for a “bi-directional” port for PC or computer communications, **OUT** for an “output” port for a printer, and **IN** for an “input” port for a bar code scanner. Users who have purchased Setra’s peripherals such as the Dymo SETRA 300 printer or the Setra SmartWand can simply plug these devices into the appropriate port and start using them. The first part of this appendix describes the RS232 command and communication protocol. The second part of the appendix describes the characteristics of the ports.

#### Interfacing a Setra Super II Scale to a Computer

The bi-directional port interface not only allows the scale to transmit data to and from a computer, but also enables a computer to control a scale. Since the baud rate and data bits of this interface are selectable (see **PORTS** soft key setup in this manual), virtually any computer or terminal with an RS232 port can be connected to the scale. Setra Super II does *not* support software handshaking and supports hardware handshaking only on the “bi-directional” port . This section describes the conventions and formats used to communicate with the Super II.

## Sending Commands to the Scale

All functions which exist on the keyboard may also be accessed by a computer or a terminal by means of the RS232 interface. Simply send the ASCII character which corresponds to a function. These characters are shown in the following table:

FUNCTION	ASCII	FUNCTION	ASCII
APW	A	ID5	Y
ID 7	B	ZERO	Z
COUNT	C	immediate print	#
ID 1	D	ID start	/
exponential	E	ID finish	\$
ID9	F	? or recall	?
GROSS/NET toggle	G	REMOTE	>
ID 6	H	0	0
integration filter	I	1	1
jump code	J	2	2
CLEAR	K	3	3
ID 3	L	4	4
ACCUMULATE	M	5	5
ID 4	N	6	6
SAMPLE	O	7	7
PRINT	P	8	8
APW quantity	Q	9	9
ID 2	R	TARGET SETPOINT	^T
ID Ø	S	LOW SETPOINT	^L
TARE	T	HIGH SETPOINT	^H
ID8	U	x counter	^X
verify	V	y counter	^Y
wake-up	W	add accumulate	^+
RESET	X	subtract accumulate	^-



Never include a carriage return or line feed in any command sequence. The scale uses any command character as a terminator for an input string.

For example, to enter a tare weight of 1000 (in the units currently being displayed), simply send "1000T". This will enter the number 1000 into the TARE register. To enter an average piece weight of 12.35, send "12.35A".

### **Sending Alphanumeric ID #s to the Scale**

Alphanumeric identification information (ID#s) may be entered into the scale through the RS232 interface.

Since Setra scales recognize upper-case ASCII characters as commands, it is necessary to begin alphanumeric entries with the "/" command or start ID character.

To enter an ID# from a computer or bar code scanner, the following string must be sent to the scale:

/ [ID string] \$ (ID register character)

The ID START (or introducer) "/" instructs the scale to ignore subsequent characters as commands. The ID FINISH (or terminator) "\$" instructs the scale to interpret subsequent characters as commands. Everything between ID START and ID FINISH will be stored as the ID string. The ID register character (see the table below) instructs the scale to enter the string identifier into the ID# register.

The following table lists all ID register characters:

ID register #	ID register character
0	S
1	D
2	R
3	L
4	N
5	Y
6	H
7	B
8	U
9	F

ID register #1, 5, 7, 8, and 9 are not cleared when the **reset** key is pressed or when the unit is powered off. These are referred to as non-volatile fields. ID register # 0, 2, 3, 4, and 6 are volatile and are cleared upon reset and powering down.

The string identifier may consist of any printable ASCII character including upper case and lower case (A-Z), numbers (0-9), punctuation (!, ., :, ? ' ") and symbols, ( ), [ ], { }, / \, +, =, \*, %, &, #, < >, @ except the "\$". It may be up to 23 characters in length. All other characters are ignored by the scale.

DO NOT SEND A CARRIAGE RETURN, <CR>, OR A LINE FEED, <LF>, WITHIN OR AFTER THE STRING IDENTIFIER.

## Receiving Data From the Scale Using the Immediate Print Mode

The immediate print command “#” causes the scale to transmit whatever number or message appears in the scale display. The value is formatted as shown below:

+/- 1 2 3 4 5 6 . c0 c1 c2 c3 CR LF

The first six digits represent the number field. A + or - sign always precedes a weight reading, and a decimal point is always transmitted, though their exact location depends on the number transmitted. Numbers with less than six digits are preceded by spaces and the sign is always adjacent to the leading digit. The specific location of the decimal point depends on the precision of the number transmitted.

“c0” is the speed mode character.

CHARACTER	MEANING
F	Scale is set to fastest speed
f	Scale is set to fast speed
(space)	Scale is set to normal speed
s	Scale is set to slow speed
S	Scale is set to slowest speed

“c1” is the “mode” character. It describes what the number being transmitted represents. The following is a list of all possible mode characters:

CHARACTER	MEANING
(space)	Number field is a message or net weight
G	Number field represents GROSS weight
T	Number field represents TARE weight
A	Number field represents APW
M	Number field represents ACCUM contents

“c2” is the “units” character. It describes the units of the number being transmitted. The following is a list of all possible characters sent in this digit:

CHARACTER	MEANING
G	Number is expressed in grams
O	Number is expressed in ounces
P	Number is expressed in pounds
Y	Number is expressed in troy ounces
R	Number is expressed in carats
D	Number is expressed in pennyweights
K	Number is expressed in kilograms
X	Number is expressed in user programmable unit
C	Number is expressed in pieces

“c3” is the “stability” character. This character corresponds to the “OK” symbol on the display.

CHARACTER	MEANING
(space)	Reading is not stable
S	Reading is stable
O	Reading is over the base capacity
U	Reading is under the base capacity

The immediate print output is always terminated with a carriage return and line feed. To read data that may be stored in a specific memory register, instruct the scale to display the data held in the particular memory register by transmitting to the scale the memory recall command “?” followed by the memory register of interest followed by the immediate print command “#”. For example, to read the contents of the following registers, the following codes must be transmitted:

Register	Transmit
Tare	?T#
Accumulator	?M#
Count	?C#
APW	?A#
Gross	?G#
Net	?GG#

The following are some examples of immediate print output:

“--- +1 2 .3 - G P S” means that the GROSS weight is 12.3 lbs stable.  
“--- +1 0 0 0 0 - C -” means 10000 pcs, and the reading is not stable.  
“---- + 8 4 .6 - T O -” means that the TARE weight is 84.6 ounces.

Note: When the “#” immediate print command is entered via the IN port, output is via the OUTport; if the input is via the BI port, output is also via the BI port.

## Interval Print Mode

For continuous data output, use the PRINT INTRVL selection in the **PRINT** soft key section of the Supervisor Menu to print the contents of the display every time a new reading or message is available. The rate at which data is updated is variable and ranges from once every 0.2 seconds up to once every 24 hours. This mode is useful if the computer scale software interface runs as a background process.

## The Jump Function

The Jump Function causes the scale to immediately operate in a given weight unit. Using this function ensures that numbers, such as tare weight or average piece weight, entered through the RS232 interface are interpreted in the correct units. For example, if the average piece weight was stored by a computer in grams, it would be necessary to ensure that the scale was operating in grams prior to sending the APW to the scale. This feature is only available through the RS232 interface.

To use the Jump Function, send an **nJ** to the scale, where “J” is the Jump function command and “n” is the unit code. The units code ranges from 0 to 7 as shown:

<b>Units Code</b>	<b>Unit</b>
0	User programmable unit (default GRAINS)
1	GRAMS
2	OZ (ounces)
3	LBS (pounds)
4	TROY (troy ounces)
5	DWT (pennyweights)
6	CARATS
7	KG

Do not send any number other than 0-7. For example, to enter an average piece weight of 0.23456 grams from a computer, send “1J0.23456A”. The “1J” sets the scale for operation in grams. The “0.23456A” tells the scale to enter that weight into the APW register. The Jump Function prevents misinterpretation of values entered from a computer.

### **The Quantity Function**

The Quantity Function operates very much like the “jump function” for the APW. By sending a numeric value followed by the letter Q, the scale will then accept the APW that follows as the average piece weight of the specified number of pieces represented by the numeric value preceding Q. For example, to send 1.2345 lbs as the APW of 1000 pieces, the scale needs to receive “3J1000Q1.2345A” (the 3J to specify the lb units, 1000Q to specify 1000 quantity, and 1.2345A to specify the APW value).

An APW with a “Q” quantity can be entered with the scale in any APW Quantity mode but will only be displayed in the entered quantity if the scale is set to the “APW Variable Quantity Mode”.

### **The Verify Function**

When many scales or other peripherals are connected to a computer, it is sometimes useful for the computer to be able to check on the status of these devices. The verify function can be used to determine the model number of a scale and determine that the scale is functioning correctly. To invoke the verify function, transmit an ASCII “V”. If the scale is functioning correctly, it will send out the following messages followed by carriage return and line feed:

```
“Model 409  
Base 1 capacity XXXXX”
```

### **Status After Power is Applied**

All Setra scales have an internal nonvolatile memory for storing certain status information. This memory does not erase when power is removed from the unit. All setup functions (such as print format, minimum pieces, minimum accuracy, baud rate, and data base information) are stored in this memory. As a result, the baud rate and print format will not need to be reset each time the scale is turned on.

During the first 30 seconds of operation, the scale will run through a self-diagnostic procedure. When the unit is ready to be used, it will identify itself by transmitting a “wake-up” message. (This message can also be invoked by sending a “W” to the scale.)

```
“Model 409  
High Precision Weighing and Counting System  
Software Rev X.XX  
Base 1 Capacity XXXXX”
```

## The RS232 Interface Hardware

Although Setra scales can communicate with almost any RS232 device, the built-in interface does not include the complete protocol. Only the transmit and receive lines of the standard interface are used on the OUT and IN ports respectively, and the transmit, receive, RTS and CTS lines on the BI port.

The default data format is:

- 1 start bit
- 8 data bits including parity
- 1 stop bit
- 10 bits per frame (framing errors ignored)

NOTE: The scale will transmit using the parity selected; however it does not check the parity it receives.

All serial ports use an eight pin modular connector. The pinout is as follows:

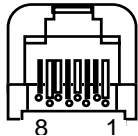
BI		OUT	IN
1. ground	 <p><b>Modular Jack Connector</b> (in back of controller)</p>	1. ground	1. ground
2. transmit out		2. transmit out	2. no connection
3. receive in		3. no connection	3. receive in
4. RTS (Request To Send)		4. Alarm 1	4. Digital Input 1
5. CTS (Clear To Send)		5. Alarm 2	5. Digital Input 2
6. no connection		6. no connection	6. +5V
7. ground		7. ground	7. ground
8. ground		8. Alarm 3	8. IN Port

NOTE: The "handshake" signals "Clear To Send" (CTS) and "Request to Send" are implemented on the BI port only. This requires that the peripheral attached to the IN and OUT ports have a minimal buffer (15 characters).

In addition, some computers requiring hardware handshaking will need a connection between two pins on the computer's connector named DTR and DSR (Data Terminal Reading and Data Set Ready).

The maximum recommended cable length is 15 meters. The cable may be longer if it has less than 2,500 pF capacitance. The load impedance of the device connected should be between 3,000 and 7,000 ohms with not more than 2,500 pF shunt capacitance. For more information, consult EIA Standard RS232: "Interface Between Data Terminal Equipment Employing Serial Data Interchange."



## ScriptCoder™ Custom Label Printing

Your Super II scale can be programmed to print custom label designs on any serial printer, limited only by the printer's capabilities. This feature, called ScriptCoder™, allows a label design or RS232 output, to be written using a series of codes which are stored in the scale's memory. The set of codes, or script, is executed each time the specific label design is selected to print. The script can be written to create a customized output to a serial dot matrix printer, thermal bar code printer, or even a data collection device. The Super II can store up to ten different scripts.

### Ways to Create and Store a Script

A script contains preprogrammed text and data which is transmitted from the scale to the printer when the appropriate print command is executed. There are four ways to create and enter a script; the best method to use depends on the complexity of the label design and the peripherals available to the programmer.

The first method may be performed using only a Super II and involves entering codes directly through the scale keypad. The second method involves the use of a QWERTY keyboard to enter a combination of characters and codes. The third method involves scanning codes into the scale using a bar code menu chart available in the ScriptCoder Label Design & Cable Kit (Setra P/N 404910). Finally, the fourth method involves writing the script using the ScriptCoder PC program and downloading it to the scale via the BI RS232 port (also available with the ScriptCoder kit).

### Entering a Script via the Super II Keypad

All of the codes required for a script may be entered directly through the scale keypad. This method is most suitable for simple label designs as shown in the following examples:

Part #: 123-456  
APW: 2.56789 g

The following transmission sequence would be required from the scale:

- transmit the text "Part #:" and one space
- transmit the contents of the ID register
- transmit one carriage return and one line feed
- transmit the text "APW:" and one space
- transmit the contents of the APW register and one space
- transmit the unit designation letter
- transmit one carriage return and one line feed (for longer spacing or to feed between labels add linefeeds or a formfeed to the end of this script to advance to the next label)

Before a script can be entered into the scale's print memory, the scale must be setup to accept the programming codes. To perform this setup, follow the instructions under soft key **PRINT** in the Supervisor Setups section of this manual. The following is the Script entry menu.

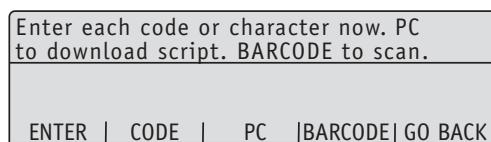

To produce the ASCII output below, enter the following script by using the numeric keypad followed by the **CODE** soft key for each code. For alphanumeric characters, enter a single character and press the **ENTER** key. To look up the numeric code associated with each character or scale function, refer to the tables on page 116 through 120.

Part #: 123-456 APW: +2.56789 G
------------------------------------

SCRIPT - Part #: (ID 0 is default register) <CR><LF>  
CODES - 80 CODE, 97 CODE, 114 CODE, 116 CODE, 32 CODE,  
35 CODE, 58 CODE, 32 CODE, 128 CODE, 13 CODE, 10 CODE

SCRIPT - APW: (APW register) (Units ltr) <CR><LF>  
CODES - 65 CODE, 80 CODE, 87 CODE, 58 CODE, 32 CODE, 141 CODE,  
32 CODE, 149 CODE, 13 CODE, 10 CODE [to add line feeds enter 10 CODE here; to add  
a form feed enter 12 CODE here.]

DONE [to end script]

Each time the **PRINT** soft key is pressed (followed by the Print Register # if not the default), the scale will output the above ASCII format and advance the printer to the next line or label.

### Entering a Script using a QWERTY Keyboard

Simple scripts, such as the ASCII output above, can be more easily programmed by connecting a QWERTY keyboard to the Super II controller. By using a combination of typed characters and numeric codes, the entire script can be entered using the QWERTY keyboard.

Before a script can be typed in using a QWERTY keyboard, the scale must be setup to accept the formatting characters and programming codes. To perform this setup, follow the instructions under soft key **PRINT** in the Supervisor Setups section of this manual.

The following is the Script entry menu.

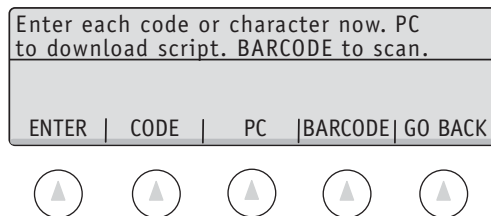

To produce the same ASCII output below, the script can be entered using the QWERTY keyboard. Type in alphanumeric characters followed by the F1 function key or numeric formatting and scale registers codes followed by the F2 function key.



Part #: 123-456 APW: 2.56789 g
-----------------------------------

SCRIPT - Part #: (ID 0 is default register) <CR><LF>  
QWERTY KEYBOARD- P (F1), 2 (F1), r (F1), t (F1), : (F1), \_ (F1),  
128 (F2), 13 (F2), 10 (F2)

SCRIPT - APW: (APW register) (Units ltr) <CR><LF>  
QWERTY KEYBOARD- A (F1), P (F1), W(F1), : (F1), \_ (F1), 141 (F2), (F1),  
149 (F2), 13 (F2), 10 (F2)[to add line feeds enter 10 (F2)  
here; to add a form feed enter 12 (F2) here.]  
(F5) [to end script]

Each time the **PRINT** soft key is pressed (followed by the Print Register # if not the default), the scale will output the above ASCII format and advance the printer to the next line or label.

### Entering a Script Using a PC

Please refer to the ScriptCoder Operator's Manual in the ScriptCoder Label Design and Cable Kit. (Setra P/N 404910)

### Entering a Script Using a Bar Code

Please refer to the ScriptCoder Operator's Manual in the ScriptCoder Label Design and Cable Kit. (Setra P/N 404910)

The following tables show the codes for the ASCII characters, ASCII control codes and Setra scale data codes.

### ASCII Characters

A	65	a	97	0	48
B	66	b	98	1	49
C	67	c	99	2	50
D	68	d	100	3	51
E	69	e	101	4	52
F	70	f	102	5	53
G	71	g	103	6	54
H	72	h	104	7	55
I	73	i	105	8	56
J	74	j	106	9	57
K	75	k	107	space	32
L	76	l	108		
M	77	m	109		
N	78	n	110		
O	79	o	111		
P	80	p	112		
Q	81	q	113		
R	82	r	114		
S	83	s	115		
T	84	t	116		
U	85	u	117		
V	86	v	118		
W	87	w	119		
X	88	x	120		
Y	89	y	121		
Z	90	z	122		

## Punctuation and Special Characters

!	33	[	91
"	34	\	92
#	35	]	93
\$	36	^	94
%	37	—	95
&	38	'	96
'	39	{	123
(	40		124
)	41	}	125
*	42	~	126
+	43	backspace	251
,	44		
-	45		
.	46		
/	47		
:	58		
;	59		
<	60		
=	61		
>	62		
?	63		
@	64		

## Setra Scale Data

ID 0	128	transmit ID field 0 "S" id
ID 1	129	transmit ID field 1 "D" id
ID 2	130	transmit ID field 2 "R" id
ID 3	131	transmit ID field 3 "L" id
ID 4	132	transmit ID field 4 "N" id
ID 5	133	transmit ID field 5 "Y" id
ID 6	134	transmit ID field 6 "H" id time
ID 7	135	transmit ID field 7 "B" id
ID 8	136	transmit ID field 8 "U" id
ID 9	137	transmit ID field 9 "F" id
Gross	138	transmit gross weight in external resolution
Net	139	transmit net weight in external resolution
Tare	140	transmit tare weight in external resolution
A.P.W.	141	transmit APW in internal resolution
A.P.W. exp.	142	transmit APW in exponential notation
Count	143	transmit count
Acc Count	144	transmit count accumulator value
Acc Ct Ents	145	transmit count accumulator entries
Acc Weight	146	transmit weight accumulator
Acc wt Ents	147	transmit weight accumulator entries
Units word	148	transmit units label, e.g., "grams" or "pounds"
Units ltr.	149	transmit units letter, e.g., "g" or "p"
Setra codes	150	ignored in scale, interpreted during setup to insert the appropriate scale control codes.
Units jump code	151	transmit units code number and J, e.g., "1J" or "3J"
X of "x or y seq."	152	transmits the X of the "X of Y" sequence.
Y of "x or y seq."	153	transmits the Y of the "X of Y" sequence.
Time	154	transmit the time hh:mm AM, from the Super II
Date	155	transmit the date mm/dd/yy from the Super II
Pause (.1)	156	Pause for a specified time before continuing to transmit the script. (Argument code 1 to 99, e.g., 5 = .5 second pause, 25 = 2.5 second pause.)
Wait for Stability	180	Pause until the weight on the scale is 'stable' or 'very stable.
Redirect Output	181	Send the output stream to another port or an ID FIELD. (Argument code 0-9 for ID FIELD, '0' for OUT port, 'B' for BI-directional port or 'I' for in IN port.

## Format Codes

Format Length	160	Set the length of the field to be printed. (Argument code 1 to 99.)
Format Precision	161	Set the precision of the field to be printed. (Argument code 0 to 6.)
Format Sign	162	Transmit the "+" and "-" sign or only the "-" sign as appropriate. (Argument code "+" or "-"; 43 or 45, respectively.)
Justification	163	Justify the field to the left or right. (Argument code "R" or "L"; 82 or 76, respectively.)
Fill Character	164	The fill is the character to be repeated in order to justify the field and create the desired length. (Argument code: any printable character, e.g., "*", "0" or space, 42, 48 or 32, respectively.)
Absolute Value	165	Convert the formatted number to absolute value
All Capitals	166	Convert all letters in print field to capitals
Wait for Stability	180	The scale will stop processing the script at code 180 if the weight is unstable and will continue once the weight becomes stable.
Redirect Output	181	When a code 181 is encountered, the scale will stop processing the script and send the processed buffer to whichever port is currently being accessed (such as the BI or OUT ports). The next character determines the new port as follows: <0> through <9>: the following script will be sent to the ID field<> B or <66> :the following script will be sent to the BI port O or <79> :the following script will be sent to the OUT port The data coming into the input port will be processed just as a stream of data coming from the barcode reader or a computer, so all SDL and RFN commands will be correctly interpreted. The functionality is used to allow information to be printed from an ID field into a register such as the Tare register. For example,

the SDL encoded print script to cause the ID0 field to be printed to the tare register is:

```
\Print 4 = "Redirect," 'bi', script  
\script = "<181>I<128>T"  
\endprint!
```

An actual script(in Super Talk) is which the net weight (script code 139) is put into an ID register(ID8 or ASCII Code BS)for storing it as follows:

```
\Print 5 + "Net 2 ID8",BI, Script  
\SCRIPT = "<181><BS><139>"  
\ENDPRINT!
```

You are allowed to format data as well. This script,  
\SCRIPT = "<181><BS><139><162><45><163>L<149>"  
would redirect (181) into ID8 (BS) the net weight (139) with the sign (162) off (45) and justification (163) would be left (L) with units letter (149) following everything.

Note: A print format is required to make use of the redirect command.

### ASCII Control Characters

soh	1	ctrl A	dcl	17	ctrl Q
stx	2	ctrl B	dc2	18	ctrl R
etx	3	ctrl C	dc3	19	ctrl S
eot	4	ctrl D	dc4	20	ctrl T
enq	5	ctrl E	nak	21	ctrl U
ack	6	ctrl F	syn	22	ctrl V
bel	7	ctrl G	etb	23	ctrl W
bs	8	ctrl H	can	24	ctrl W
ht	9	ctrl I	em	25	ctrl Y
lf	10	ctrl J	sub	26	ctrl Z
vt	11	ctrl K	esc	27	
ff	12	ctrl L	fs	28	
cr	13	ctrl M	gs	29	
so	14	ctrl N	rs	30	
si	15	ctrl O	us	31	
dle	16	ctrl P	del	127	

## Setra Dialog Language

### SDL Principles

The Setra Dialog Language (SDL) is a powerful tool that can be used to setup and control the 409 Super II scale. There are SDL instructions to set operating configurations, program Macros, set up print formats, enter and output database, transaction log, register data and execute scale functions.

All output from SDL is in the same format as SDL input commands so that SDL output can be sent directly back into the scale or into another 409 Super II scale. This feature allows all the scale setups and database records to be backed up externally and then restored by transmitting the data back into the scale. Setups or data records can be transferred directly from one scale to another.

### SDL Syntax

General rules for the Setra Dialog Language:

All commands begin with a '\ character (required to alert the scale that the following command is not in RFN)

All commands end with a carriage return (and optional linefeed).

Extra whitespace characters are ignored (space, tab, linefeed, etc.).

Each command consists of an object (such as Tare or an ID register) and an action (such as execute or set). Some objects may have an index set associated with it, and some actions may have one or more data values. Some data values may also have an optional weight unit designation (such as grams); in no units are given, the value will default to the presently active units.

In the case of more complex objects such as print formats or prompting macros, the initial command will start a sub command mode so that individual fields or steps may be defined with subsequent commands. This sub command will exit when the corresponding END command is given (e.g. ENDPRINT ends the print definition sub command code).

Comments are preceded with a semi-colon '; All characters between the semi-colon and the carriage return will be ignored.

All names including object names, index names, and data token names may be truncated according to the rules of minimum letter uniqueness. (see section below for explanation of minimum letter uniqueness).

The command actions are:

=	Set	Sets the value of the object
?	Inquire	Reports the value of the object
!	Execute	Performs operation of the object
+	Enable	Enable the object
-	Disable	Disable the object

The response to the "?" inquire command is formatted like the corresponding set command so that the output can be feed back to the controller as an RFN set command to the set object. For more compact communications, a special SDL Terse output mode can be selected in which the command outputs are abbreviated with minimum letter uniqueness.

The basic form (prototype) of a command is:

`\ Object [ index ] { ! | ? | = value [ units ] | + | - } [ ; comment ]`

Nomenclature:

<u>CAPITALS</u>	Words shown in all capital letters are key words ( Object names, data tokens). Letters required for minimum letter uniqueness are underlined.
<i>data values</i>	User supplied data are in italics
[ <i>data</i> ]	Optional data items are shown in square brackets.
{ <i>data</i>   <i>data</i>   ...   <i>data</i> }	When input data is one of several options, the possible selections are shown in curly brackets separated by bars.
<i>units</i>	Units are indicated by a unit name or abbreviation (e. g. grams, oz, # dwt, etc.)

Examples:

Performing a tare:

`\ TARE !`

Outputting the Lot Number:

`\ LOT ?`

Setting the filtering speed of base 3 would be accomplished with this command.

`\ SPEED 3 = FAST`

Enabling Macro 3:

`\ MACRO 3 +`

### **Minimum letter uniqueness**

The name of an object may be truncated to the minimum number letters that are unique to that object. Example: In the list of objects { TARE, PRINT, PROMPT }, TARE can be represented as T, TA, TAR or TARE. PRINT can be represented by at least PRI to distinguish it from prompt which also begins with PR.

SDL Command Set:

Transferring Setups

SETUPS - Non-volatile setups

SETUPS = "*Setups Name*" ; Name the present setups

SETUPS { ALL | CONTROLLER | BASIC | BASES | MACROS | PRINTS | DATABASE | TRANSACTION | } ?

Output the selected group of setups



Scale Non-volatile Setups

**HYSTERESIS** - Display hysteresis

HYSTERESIS +

HYSTERESIS -

HYSTERESIS ?

**USERUNIT** - User defined UNit

USERUNIT

# Appendix D

## Battery Option

### Installation

Disassembly of the scale is required when installing the battery option kit.

1. Remove the pan and the pan support by removing the 3 screws marked "A" in Figure 1.
2. Remove the (2) Phillips head screws (marked "B" in Figure 2) and the rear panel.
3. Next remove the (4) Phillips head screws holding the rear power circuit board to the base casting.
4. Disconnect the rainbow cable and coiled cord. Remove the rear power circuit board.
5. Install the battery option circuit board and reconnect the rainbow cable and coiled cord. Make sure to loop the battery connector out through the battery door opening.
6. Replace the (4) Phillips head screws to hold down the battery option circuit board.
7. Exchange the rear panel with the panel cut to accommodate the ON/OFF switch. Mount the new rear panel onto the scale with the (2) Phillips head screws (marked "B" in Figure 2).
8. Remove the battery door, attach the battery connector to the battery, then insert the battery (cable end first) completely into the scale.
9. Replace the battery door, the pan and pan support.
10. The scale is now powered for portable operation.

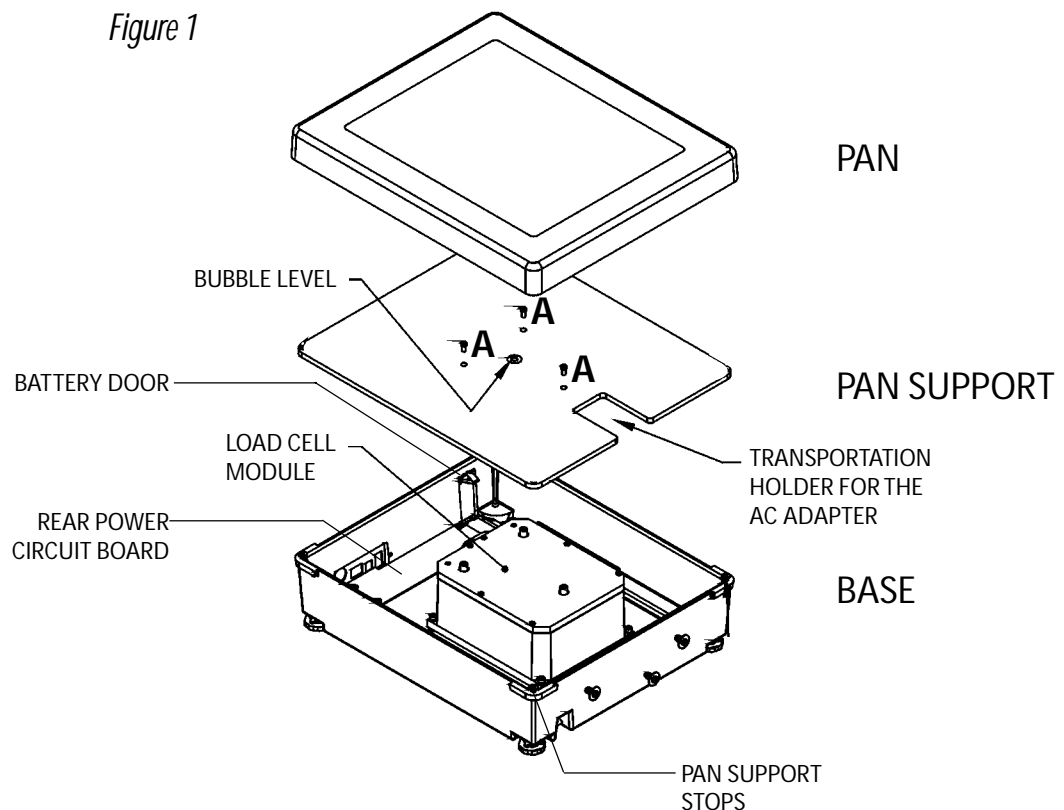
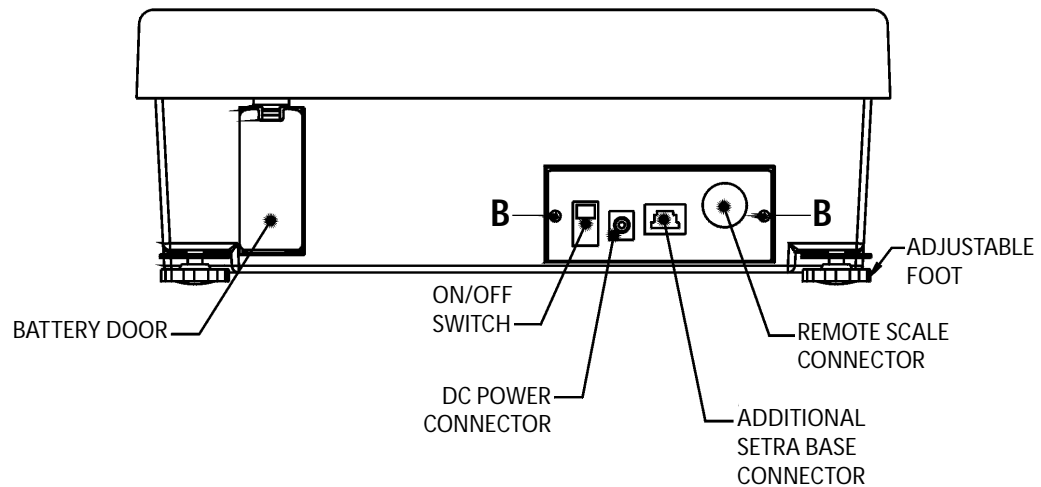

Figure 2



### Battery Use for Portable Operation

A fully charged battery will allow the Setra Super II to operate for approximately 14 hours before recharging is needed. The battery will last two-thirds as long if the scale is equipped with either a backlight display, a remote Scale Option or bar code scanner. The "low battery" indicator light on the front panel of the scale will light up approximately 15 minutes before recharging is necessary. When battery power is too low for proper scale operation, the circuit will automatically shut off the battery and the scale will cease operation.

Replacement batteries can be ordered from Setra Systems (part number 409740).

### Battery Charging

When the "low battery" indicator light on the front panel of the scale turns on, use the following procedure to recharge the battery:

1. Plug the AC adapter (Setra part number 404712) into an electrical outlet and plug the power cable into the scale. Do not remove the battery. The scale will automatically recharge the battery from the electrical outlet.
2. The "low battery" indicator light will remain on during recharge until the battery reaches 40% of its rated capacity. This will take about 2.5 hours with the scale power switch in the "ON" position, and two hours and ten minutes with the switch "OFF". A battery powering a scale alone will reach 95% of its rated capacity in 8 hours if the power switch is in the "ON" position and in 7 hours if the switch is "OFF". Note that the indicator light will not light up if the scale switch is "OFF".
3. If the scale is equipped to power a Remote Scale Option or a bar code scanner from the scale's battery, it is recommended that battery recharging be done with the scale power switch in the "OFF" position.
4. The charging indicator light on the front panel of the scale will stay on until the battery reaches 95% of its rated capacity. Note that the charging light will not be lit if the scale power switch is in the "OFF" position. Battery recharging time may vary slightly depending upon the temperature in the scale operating environment.

### Battery Storage

When storing your scale for an extended period of time, it is recommended that you disconnect your battery completely from the recharging unit. Always recharge the battery before storage to prevent damage to the battery.

## Strain Gauge Load Cell Remote Scale Option

### Installation

Disassembly of the scale is required when installing the optional strain gauge load cell base analog to digital signal conversion PCB.

1. Remove the pan and the pan support by removing the 3 screws marked "A" in Figure 1.
2. Pop out the round connector plug from the hole marked "Remote Base" on the back cover.
3. Locate the two threaded holes in the left side of the bottom of the base casting (as viewed from the front of the base). Start a 6-32 x 3/8" screw into each of the holes and turn them two revolutions each.
4. Refer to Figure 2. Pick up the circuit board and bracket assembly and orient it so that the flange with two slots is downward and the 6-pin DIN connector faces the back. Lift the coil cord upward to the left and insert the bracket assembly into the base casting between the coil cord and the load cell assembly, so that the straight section of the cord is against the back edge of the bracket assembly above the DIN connector (circuit board face the load cell assembly).
5. Slide the circuit board back until the bottom of the bracket touches the back of the base casting and then slide the bracket to the left so that the flange slots slide around on the 6-32 x 3/8" screws. The coil cord should lie between the bracket and the left side of the base casting.
6. Tighten down the 6-32 x 3/8" screws to hold the bracket in place.
7. Connect the Strain Gauge Remote Scale Option circuit board cable to the 10 pin header between the two RJ-45 jacks on the Rear Power Circuit Board.
8. Reinstall the pan and pan support with the 3 screws.
9. The scale is now ready for Remote Base calibration and operation.

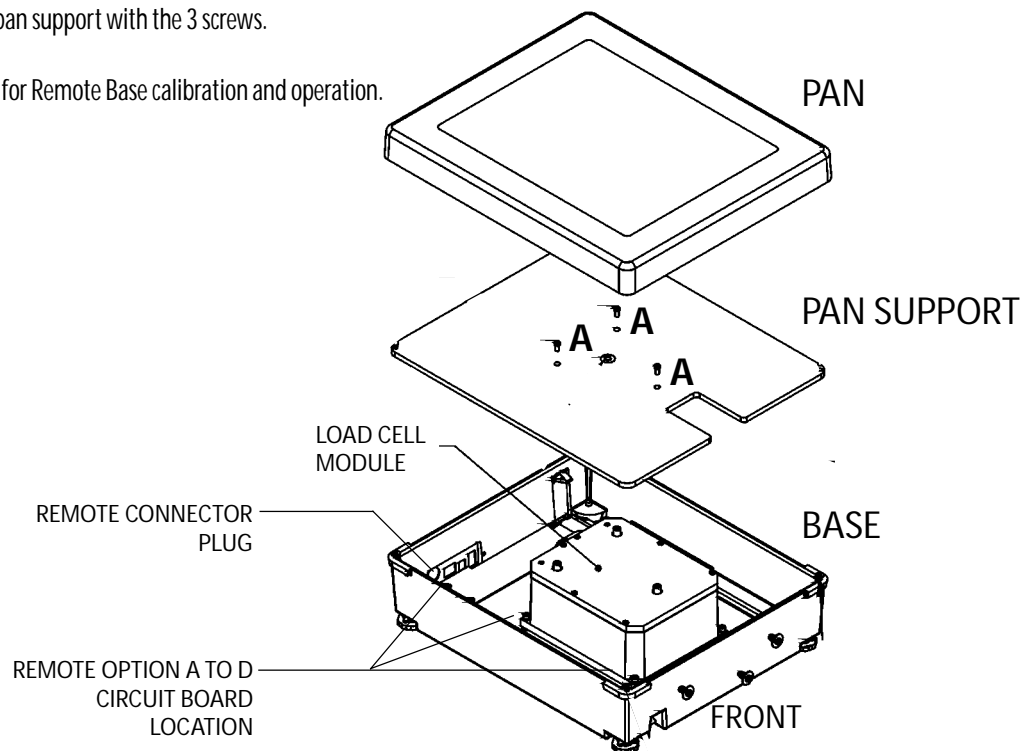

Figure 1. Exploded view of Super II before Remote Scale Option Installation

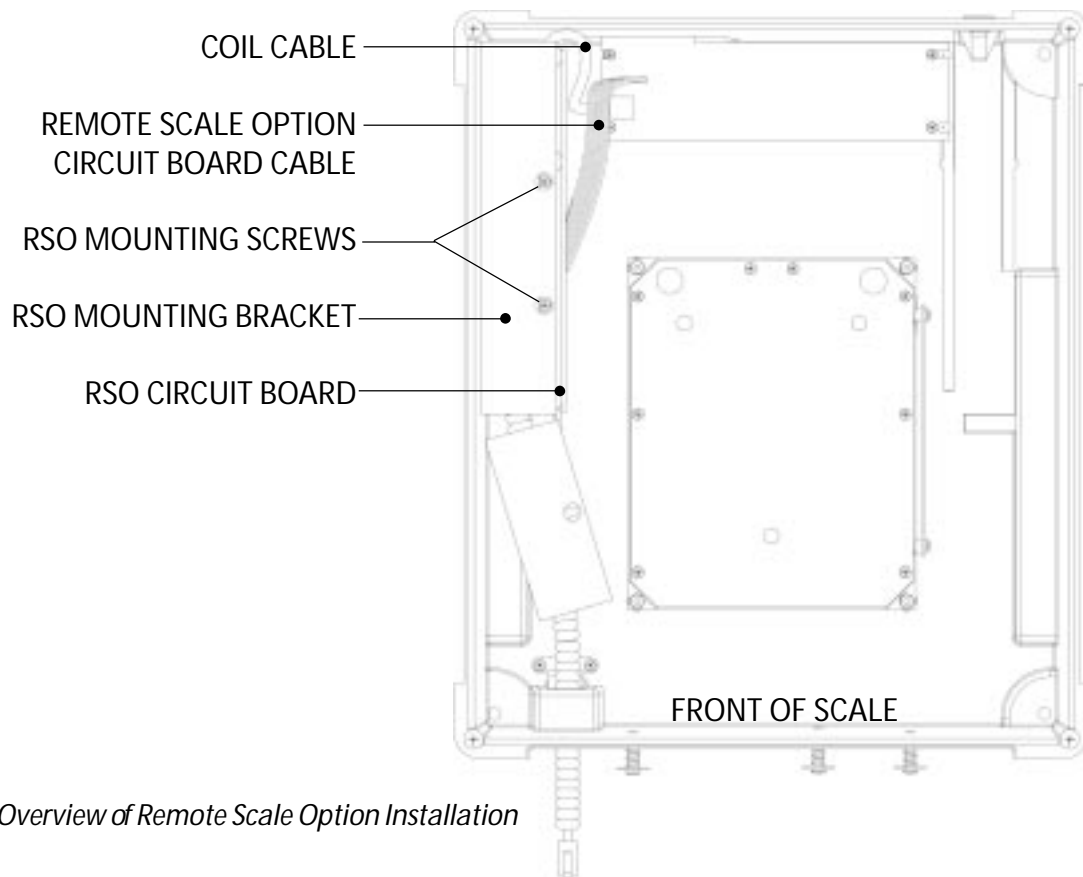

Figure 2. Overview of Remote Scale Option Installation

### Connect to Wiring

If the cable connector of the remote scale base is physically compatible with the 6 pin circular DIN connector on the back of the Super II scale, proceed to Figures 4 and 5 to verify that it is **electrically** compatible. Otherwise, damage may be caused to both the Super II scale and the remote scale base.

If the cable connector of the remote scale base is **not** compatible with the 6 pin circular DIN connector on the back of the Super II scale, follow the procedures directly below.

NOTE: DISCONNECT THE SUPER II SCALE AND REMOTE SCALE BASE FROM ITS POWER SOURCE BEFORE PERFORMING THE FOLLOWING PROCEDURES.

1. Remove the existing remote scale base connector.
2. Taking the connector supplied, separate the cord guard and metal housing by removing the screw.
3. Slide the metal housing onto the cable of the remote scale base. (See Figure 3.)
4. Strip 1/2" of the cable insulation.

NOTE: Do not nick, scrape or cut foil or braided shield when stripping cable insulation. Be equally careful not to mar the wire insulation when stripping the shield or conductors when stripping the wire insulation.

5. Fold back the shield and strip 1/10" from each wire.

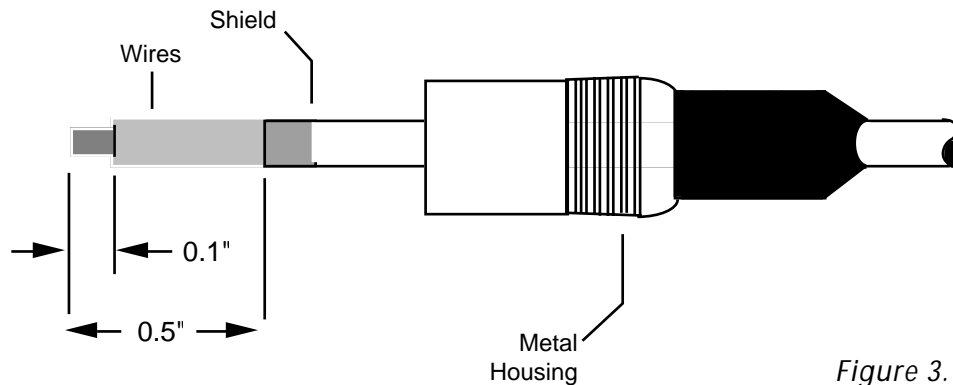

Figure 3. Cable Preparation

6. Following the wiring diagram in Figure 4, solder each wire to the pin contact.
7. Make sure all of the wires do not make contact with each other, then crimp the plug extension to the shield of the cable, solder to secure, if possible.
8. Slide the metal housing over the plug and secure with the screw using a small screwdriver.

Figure 4. View from solder end of shielded DIN plug connector

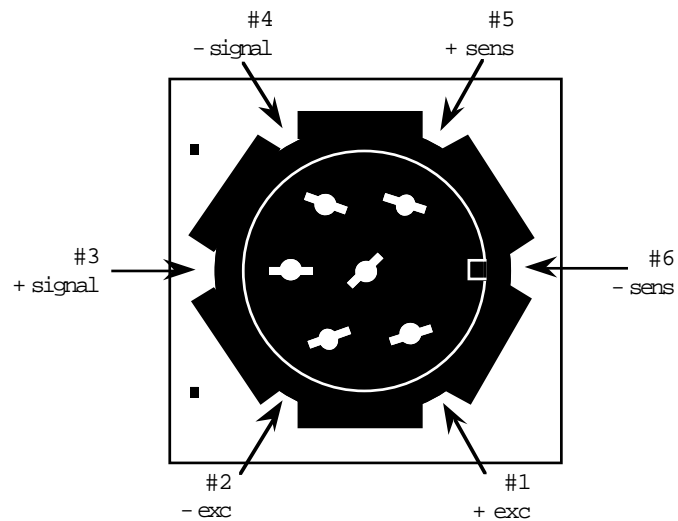
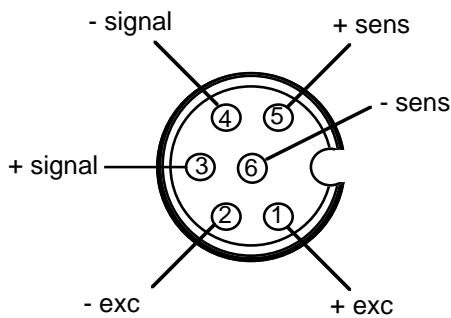

Figure 5. 6 Pin circular DIN Connector on back of Super II Scale

## Calibration

The calibration of the Strain Gauge Load Cell Remote Scale Option is accessed through the **BASECOM** soft key of the CALIB menu in the Bases Setups (see CALIB section in this manual). Before entering the BASECOM selections, make sure that the controller is monitoring the Strain Gauge Load Cell Remote Base by entering the proper Base address number with the remote key.

Upon entering the BASECOM mode, the following screen will appear:  
(User input is shown in bold)

```
Select a function and press ENTER
1) Test modes
2) Calibration
3) Set sampling res.
4) Escape
NO | YES | ENTER | | END
```



Press 2 and then press **ENTER**.

```
Present calibration data will be lost.
Continue calibration?
(enter YES or NO)
NO | YES | ENTER | | END
```



Press the **Yes** soft key.

```
Select calibration units and press ENTER
1) Grams
2) Kilograms
3) Pounds
4) Ounces
NO | YES | ENTER | | END
```



Press the number for the desired units (**1-4**) followed by **ENTER**.

```
Enter full scale capacity of the
remote base and press ENTER
NO | YES | ENTER | | END
```



Using the numeric keys enter the value of the full scale capacity in the selected weight unit and press **ENTER**.

Enter the display resolution and  
press ENTER

NO | YES | ENTER | | END



Enter the desired display resolution increment in the selected weight unit and press **ENTER**.

Note: The display resolution cannot be greater than 1/50,000 of full scale capacity.

Enter calibration weight  
and press ENTER  
(for best results, calibration weight  
should be 25% or more of capacity)

NO | YES | ENTER | | END



Enter the value of the calibration weight and press **ENTER**.

Remove all weight from scale base  
and press ENTER

NO | YES | ENTER | | END



Remove all weight from the scale pan and press **ENTER**.

Acquiring stable weight - please wait

NO | YES | ENTER | | END



Wait while a stable reading is acquired.

Place (*calibration weight*) (*units*) on scale base  
and press ENTER

NO | YES | ENTER | | END



Place the previously entered calibration weight on the scale pan and press **ENTER**.



Acquiring stable weight - please wait

NO | YES | ENTER | | END



Wait while a stable weight reading is acquired.

Remove all weight from scale base  
and press ENTER

NO | YES | ENTER | | END



Remove all weight from the scale pan and press **ENTER**.

Acquiring stable weight - please wait

NO | YES | ENTER | | END



Wait while a stable weight reading is acquired.

Enter END to exit factory menu

NO | YES | ENTER | | END



Press **END**.

# Appendix F

## Relay Box

### **BACKGROUND:**

There are two versions of the relay box: the indicator version and the control version. The indicator version has a stacked LED indicator light mounted on top, and is used to indicate the weight condition on the scale. The indicator displays a green, yellow or red light when an alarm is activated. The control version is used to isolate the checkweigher from the harsh conditions of a factory floor, as well as allowing the scale to control electrical equipment that operates a different voltage than the scale. The control relay box has an electrical signal output. The relay box consists of an enclosure box, a circuit board, three relay modules, one or two modular jacks, and a power jack. The indicator relay box also includes the indicator light.

The circuit board has screw terminals for wiring, as well as four slots for relay modules. The relay box has three slots populated with relay modules. The relay modules are DC output type, allowing a 5VDC signal to control 5-60VDC output signal. There are two rows of screw terminals on the circuit board, the inputs (marked 'CONTROL' on the circuit board) and the outputs ('FIELD').

The inputs generally come from the scale, and the outputs go to process equipment, or a Setra stacked indicator light. The input is a voltage signal that is either 0 volts (low) or 5 volts (high). On the top of each relay module is a small red LED that lights when the input is high (separate from the stacked 'indicator light'). The led can only be seen when the cover of the relay box is removed. The output is a switch that is open when the input is low, and closed when the input is high.

### **INDICATOR RELAY BOX SETUP:**

The indicator light version is pre-wired at the factory for easy setup. Simply plug the modular cable into IN port on the relay box, and connect it to the OUT port on the Checkweigher. Then, plug the DC adapter into a wall outlet, and the DC barrel jack on the relay box. The indicator light is now ready for use. When used as configured from Setra, alarm 1 controls the yellow light, alarm 2 controls the green light, and alarm 3 controls the red light. This behavior can be changed fairly easily by rewiring the modular jack inside the box. To switch the color used for two different alarms, switch the + terminal wires. The wiring as received from the factory is shown in Table 1.

### **CONTROL RELAY BOX SETUP:**

The version of the relay box used for control of process equipment requires some configuration before it is ready for use. There are two modular jacks on this version. The modular jack on the 'CONTROL' side of the box (same side as the power jack) has already been wired to be controlled by the three alarm outputs of the Checkweigher. When using the factory wiring, the terminal assignment is shown in Table 2. Operation of the box can be verified by viewing the led lights on the top of the relay modules. Configure the alarm outputs of the checkweigher and turn them on using the menus in the checkweigher controller. Remove the cover of the relay box. Then plug the cable into the relay box and into the OUT port of the checkweigher. As the alarm output state changes the status of the LED lights will change. When alarm state is high the LEDs are lit and the output switch is closed.

Next, wire the second modular jack to the 'FIELD' side of the circuit board. Two examples are provided that show how to wire the second modular jack. If switched output is desired (that is, a normally open switch that closes when the alarm is high) then wire the second modular jack as shown in Table 3. If open drain output is desired, wire the switch as shown in Table 4. The DC jack can be used to provide external power to a contact. Once the relay box has been tailored to your needs, reinstall the cover. Connect the IN port on the relay box to the OUT port on the checkweigher using the modular plug cable. Then connect the

equipment that is being controlled into the OUT port on the relay box.

**UPGRADING:**

The relay box comes equipped from Setra for most control applications. However, some applications will require control of signals outside the specifications tolerable by the stock configuration. In these cases, additional modules or circuit boards can be purchased directly from OPTO22. Different varieties of OPTO22's G4 modules are configured to control different field signals. Some examples are the G4ODC5A, which controls up to 200VDC of field voltage and the G4OAC5 that controls up to 140VAC of field voltage, as well as many others. The standard circuit board can only accept output type modules, but an input style circuit board, G4PB4, can be used to condition input signals to the scale's digital inputs. The wiring of such a unit is outside the scope of this document, please refer to OPTO22's documentation.

**RELAY BOX SPECIFICATIONS:**

Control Voltage	: 4 – 8 VDC
Control Current	: 12mA @ 5VDC
Field Voltage	: 5 – 60VDC
Field Current	: 3000mA @ 25°C, 2000mA @ 70°C
One Second Surge Current	: 5000mA
Maximum Leakage Current	: 1mA @ maximum voltage
Maximum Field Voltage Drop	: 1.6V
OPTO22's Circuit Board P/N	: G4BP4R
OPTO22's Module P/N	: G4ODC5

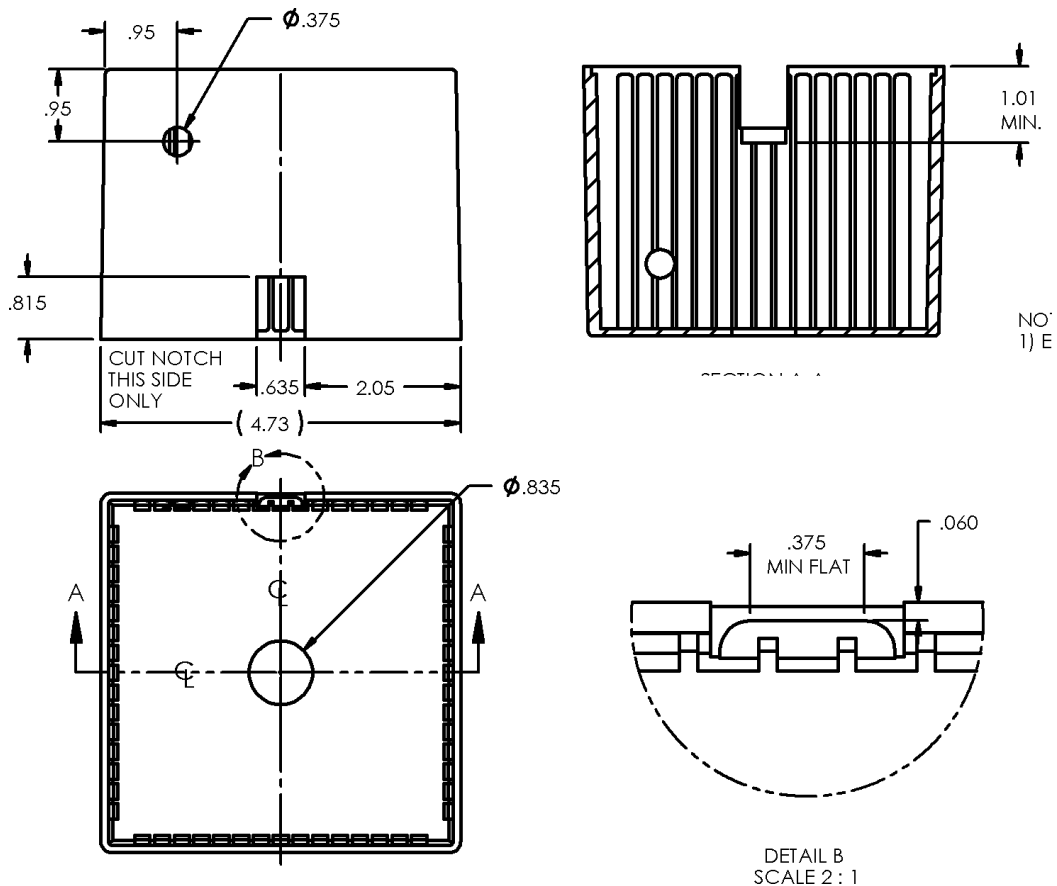

Terminal	Wire
Control 2	None
Control 3	None
Control 4	In Jack, Red
Control 5	In Jack, Blue
Control 6	In Jack, Green
Control 7	Buss wire to Control 9
Control 8	In Jack, White
Control 9	In Jack, Brown
Field 2	None
Field 3	Power Jack, Red Stack Light, Yellow
Field 4	Stack Light, Red
Field 5	Buss wire to Field 7
Field 6	Stack Light, Yellow
Field 7	Buss wire to Field 9
Field 8	Stack Light, Green
Field 9	Power Jack, Black

Table 1. Factory Default Wiring for Indicator Light Version.

	CONTROL Terminals	FIELD Terminals
ALARM 1	+ Terminal 8 - Terminal 9	Terminal 8- Terminal 9
ALARM 2	+ Terminal 6 - Terminal 7	Terminal 6 Terminal 7
ALARM 3	+ Terminal 4 - Terminal 5	Terminal 4 Terminal 5
EMPTY SLOT	+ Terminal 2 - Terminal 3	Terminal 2 Terminal 3

Table 2. Screw Terminal Assignments. Plus five volts across the + and – control terminals will cause the normally open field terminals to close.

Terminal	Wire
Control 2	None
Control 3	None
Control 4	In Jack, Red
Control 5	In Jack, Blue
Control 6	In Jack, Green
Control 7	Buss wire to Control 9
Control 8	In Jack, White
Control 9	In Jack, Brown
Field 2	None
Field 3	None
Field 4	Out Jack, Yellow
Field 5	Out Jack, Green
Field 6	Out Jack, Red
Field 7	Out Jack, Black
Field 8	Out Jack, Orange
Field 9	Out Jack, Blue

Table 3. Wiring Chart for Switched Output Example. Using this diagram, pins 1 and 2 of the modular jack are closed when alarm 1 is high, pins 3 and 4 are closed when alarm 2 is high, and pins 5 and 6 are closed when alarm 3 is high.

Terminal	Wire
Control 2	None
Control 3	None
Control 4	In Jack, Red
Control 5	In Jack, Blue
Control 6	In Jack, Green
Control 7	Buss wire to Control 9
Control 8	In Jack, White
Control 9	In Jack, Brown
Field 2	None
Field 3	None
Field 4	Out Jack, White
Field 5	Out Jack, Blue
	Out Jack, Brown
Field 6	Out Jack, Green
Field 7	Buss wire to Field 5
Field 8	Out Jack, Red
Field 9	Buss wire to Field 7

Table 4. Wiring Chart for Open Drain Output Example. Using this chart, the outputs are high impedance when the alarm is low, and connected to ground when the alarm is high. The pinout on the OUT port is the same as the IN port.

Modular Jack Pin	Function
1	Ground
2	No connection
3	No connection
4	Alarm 1
5	Alarm 2
6	No Connection
7	Ground
8	Alarm 3

Table 5 - Pinout of the IN port as wired from the factory

Wire	Color
1	Blue
2	Orange
3	Black
4	Red
5	Green
6	Yellow
7	Brown
8	White

Table 6 - Mod Jack Wire Colors

# Glossary of Terms

<b>Accuracy</b>	The degree of conformity of a measured value to the true value.
<b>APW Enhancement</b>	A scale feature whereby the scale uses a preliminary average piece weight to count parts, allowing the operator to increase the sample size without hand counting. When the targeted sample size is obtained the average piece weight is recalculated for final counting with greater precision.
<b>Average Piece Weight</b>	The value calculated by dividing the quantity of parts in the sample into the weight of the sample. This value is stored in the scale and divided into the weight of the bulk load to provide a total count.
<b>Base</b>	The portion of the scale that receives the load to be weighed.
<b>Baud Rate</b>	The rate at which a scale transmits or receives information to or from a computer or peripheral device.
<b>Controller</b>	The portion of the scale that includes the keypad, display, battery status LED's and ports for communicating with the scale base and peripheral devices.
<b>Counting Capacity</b>	The largest number of pieces that can be shown on the controller's display.
<b>Counting Resolution</b>	(Also, "internal counting resolution" or "internal resolution") The ratio of a scale's capacity to the weight of the lightest part placed on a scale's weighing element which can be counted in increments of one part.
<b>Displayed Resolution</b>	The ratio of the weighing capacity of the scale to its readability.
<b>Display Hysteresis</b>	The tendency of a scale, with a fluctuating reading, to stabilize on the most consistent value.
<b>Dual Scale System</b>	A counting system usually involving a low capacity local base for sampling and a high capacity remote base for weighing the bulk load.
<b>Gross Weight</b>	The weight of the contents (net weight) combined with the weight of its container (tare weight).
<b>ID</b>	Abbreviation for "identifier". An identifier can be a part number, lot number, or item description and can be entered into one of several available fields in the data base.
<b>Kitting</b>	The counting procedure that involves repeatedly counting out small quantities of a given part to be packaged with other parts that will be used together in an assembly.

<b>Macro</b>	A series of preprogrammed scale functions that are initiated by a keypress, and by means of display prompts, will guide an operator through a weighing or counting operation.
<b>Menu</b>	Refers to the numerous choices presented in the display as labels for the soft key. Also, the hard key that provides access to additional scale features.
<b>Minimum Accuracy</b>	The setting expressed as a percentage that determines the smallest sample weight required to count uniform parts with an error that is no larger than that selected.
<b>Net Weight</b>	The weight of the contents of a container, without the weight of the container.
<b>Parity</b>	A bit used to check the validity of the data word.
<b>Precision</b>	The degree to which a weight measurement deviates from the average of repeated measurements, usually expressed as one standard deviation (or one sigma).
<b>QWERTY</b>	Term used to describe the typical keyboard found on a personal computer or type writer. QWERTY refers to the top row of letters on the keyboard.
<b>Readability</b>	The smallest weight increment shown on a display.
<b>Register</b>	A memory location within the scale where specific data is stored.
<b>Remote Scale</b>	One or more additional Setra or strain gauge load cell bases, that are accessed by means of the "remote" key on the controller keypad.
<b>Reproducibility</b>	See "PRECISION"
<b>Resolution</b>	The smallest change in mechanical input which produces a detectable change in the output signal.
<b>Set Points</b>	Target weight or count values that can be entered into the scale for filling or check weighing applications. Set Points can be used to indicate when a weight or count is within a specified range.
<b>Span</b>	The calibration point which when combined with zero determines the slope of the line that tracks the measured weight values as a function of applied load.
<b>Tare</b>	The weight of an empty container. Also, the process of storing the weight of an empty container and zeroing the scale's display.
<b>Transaction Log</b>	A location in the scale's database where the results from each counting or weighing operation are stored in chronological order.
<b>Unit of Measure</b>	One of several available measures of weight such as grams, kilograms, pounds or ounces.
<b>Zero Tracking</b>	Automatic subtraction of small changes in weight readings due to temperature or other environmental factors to maintain a displayed reading at zero over an extended period of time.

## Appendix H

### SPECIFICATIONS

CAPACITY	READABILITY	REPRODUCIBILITY	NON-LINEARITY
4.4 lb	0.00005 lb	± 0.00005 lb	± 0.000005 lb
11 lb	0.0001 lb	± 0.0001 lb	± 0.0001 lb
27 lb	0.0005 lb	± 0.0005 lb	± 0.00005
35 lb	0.0005 lb	± 0.0005 lb	± 0.00005
55 lb	0.001 lb	± 0.001 lb	± 0.001 lb
65 lb	0.001 lb	± 0.001 lb	± 0.001 lb
110 lb	0.002 lb	± 0.002 lb	± 0.002 lb

CAPACITY	READABILITY	REPRODUCIBILITY	NON-LINEARITY
2,000 g	0.02 g	± 0.02 g	± 0.02 g
5,000 g	0.05 g	± 0.05g	± 0.05 g
12,000 g	0.2 g	± 0.2 g	± 0.2 g
16,000 g	0.2 g	± 0.2 g	± 0.2 g
25,000 g	0.5 g	± 0.5 g	± 0.5 g
30,000 g	0.5 g	± 0.5 g	± 0.5 g
50,000 g	1.0 g	± 1.0 g	± 1.0 g



## **CONTROLLER**

<b>Display type:</b>	GraphicsLCD
<b>Display units:</b>	Grams, Ounces (avoir du poids), Pounds, Pennyweights (dwt),Troy ounces, Carats, Kilograms, Grains, User -definable units
<b>Display resolution:</b>	Selectable
<b>Display update rate:</b>	Selectable from 5 settings.
<b>Internal resolution:</b>	Selectable to 1 part in 1,000,000
<b>Counting accuracy:</b>	Selectable from 90% to 99.99%
<b>Counting capacity:</b>	9,999,999 pieces
<b>Data entry:</b>	Numeric keypad with alpha-register and changeable soft keys QWER TY keyboard connectivity
<b>Printing:</b>	10 programmable print registers
<b>Database:</b>	Up to 2193 records for database and/or transaction log  10 programmable macros for step by step prompting operations
<b>Macro operation:</b>	Up to 8 bases in any combination of Setra or strain gauge bases
<b>Multiple base connectivity:</b>	3 RS232 ports:
<b>Data communications:</b>	1 IN port for bar code scanner* 1 OUT port for printer** 1 BI bidirectional port for computer device or PC
<b>Selectable baud rates:</b>	1200, 2400, 4800, 9600
<b>Selectable parity:</b>	8NONE, 7ODD, 7EVEN
<b>Dimensions:</b>	10 <sup>1</sup> / <sub>2</sub> " L x 4 <sup>1</sup> / <sub>2</sub> " W x 2 <sup>1</sup> / <sub>2</sub> " H (with rear foot installed) (27 cm L x 11 cm W x 6.5 cm H)
<b>BASE</b>	Cast aluminum housing
<b>Construction:</b>	
<b>Dimensions:</b> <b>(25 - 50 kg)</b>	12 <sup>1</sup> / <sub>2</sub> " W x 14 <sup>3</sup> / <sub>4</sub> " D x 4" H (with feet retracted) (31.5 cm x 37.5 cm x 10 cm)
<b>(12 - 16 kg)</b>	11 <sup>1</sup> / <sub>2</sub> " W x 9 <sup>1</sup> / <sub>4</sub> " D x 4 <sup>3</sup> / <sub>4</sub> " H (with feet retracted) (29 cm x 24 cm x 10.5 cm) Stainless steel

\* Setra barcode scanner options include the Smart Wand (p/n 403674) and the Linear Imager Gun for Scale (p/n 403678).

\*\* Setra printer options include the Dyno SETRA 300(p/n 401160).

**PAN**

**Construction:**

**Dimensions:** 13" W x 15 1/4" D x 1 1/2" H  
(25 - 50 kg) (33 cm x 24 cm x 4 cm)

(12 - 16 kg) 11 1/2" W x 14" D x 1 1/2" H  
(29 cm x 24 cm x 4 cm)

**DIMENSIONS**

**Overall:** 13" W x 15 1/4" D x 4 1/2" H  
(25 - 50 kg) (33 cm x 38.5 cm x 11.5 cm)

(12 - 16 kg) 11 1/2" W x 9 1/2" D x 4 3/4" H (with feet retracted)  
(29 cm x 24 cm x 12 cm)  
(2 - 5 kg) 6 1/4" round

**With controller attached:** 13" W x 19" D x 4 1/2" H  
(25 - 50 kg) (33 cm x 48 cm x 11.5 cm)

(2 - 16 kg) 11 1/2" W x 9 1/2" D x 4 3/4" H (with feet retracted)  
(29 cm x 35 cm x 12 cm)

**GENERAL**

**Operating temperature:**

40 ° to 110 °F (5 ° to 43 °C)  
10 - 90% RH non-condensing

**Power requirements:**

12 - 16V DC @ 800mA  
US AC adapter: 16 V DC @ 550m A  
Optional 12VDC @ 500m A EC fpr 230 VAC, 50Hz

**Shipping weight:**  
(25 - 50 kg)

Base: 33 lbs (15 kg)  
Controller: 3 lbs (1.5 kg)  
Combination: 35.5 lbs (16 kg)

(2 - 16 kg)

Base: 16.8 lbs (7.5 kg)  
Controller: 3 lbs (1.5 kg)  
Combination: 19.8 lbs (9 kg)

## WARNINGS

**WARNING:** IF THIS EQUIPMENT IS USED IN A MANNER NOT SPECIFIED BY THE MANUFACTURER, THE PROTECTION PROVIDED BY THE EQUIPMENT MAY BE IMPAIRED



USE SETRA REPLACEMENT BATTERY ONLY, PN 409740, LEAD-CALCIUM TYPE BATTERY.



POSSIBLE PINCH POINT. DO NOT PLACE FINGERS BETWEEN LOAD PLATE AND CHASSIS.

**WARNING:** DO NOT IMMERSE SCALE

**WARNING:** INDOOR USE ONLY

**CLEANING :** To clean the scale, use a damp cloth on the exterior of the scale. Do not clean with solvents.

## Setra Systems, Inc. Limited Two-Year Scale Warranty

Setra Systems, Inc. warrants the scales it manufactures to be free from defects in material and workmanship. Upon return, transportation charges prepaid, to Setra's factory within two (2) years of the date of purchase, Setra will repair or replace, at its option, any scale which it determines to contain defective material or workmanship and will return said scale to purchaser, transportation prepaid, at any point in the United States. Setra shall not be obligated, however, to repair or replace scales which have been repaired by unauthorized parties, abused, improperly installed, altered, or otherwise misused or damaged, even if by accident, in any way. Setra will not be responsible for any dismantling, reassembly or reinstallation charge.

Nothing in this warranty shall be construed as a warranty for merchantability or fitness for any specific use or purpose, and this warranty is in lieu of all other warranties, express or implied. Setra shall not be held liable under the terms of this warranty for any special, indirect, incidental or consequential damages claimed in connection with the scale's performance or availability.

Setra Systems, Inc.  
Weighing Systems Division  
159 Swanson Road  
Boxborough, MA 01719  
(978) 263-1400  
1 (800) 257-3872  
Fax (978) 635-9551



## EC Declaration of Conformity

The product manufacturer,  
**Setra Systems, Inc.**  
159 Swanson Road  
Boxborough, Massachusetts 01719  
U.S.A.

This Declaration of Conformity  
is in accord  
with European Standard EN 45014  
*General Criteria for Supplier's  
Declaration of Conformity.*

The basis for the criteria can be found in  
international documentation, particularly in  
ISO/IEC, Guide 22, 1982, *Information on  
Manufacturer's Declaration of Conformity  
concerning standards and other technical  
specifications.*

This declaration is an  
EC Type Declaration of Conformity  
as referenced in article 10.1 of  
EC directive 89/336/EEC  
*The EMC-directive*  
and as in Appendix III.B of  
EC directive 73/23/EEC  
*The Low Voltage Directive*

declares under its sole responsibility that the product,  
**Super II™ Electronic Weighing and Counting Scale**  
to which the declaration relates is in conformity with the following European  
harmonized and published standards as of the date of this declaration;

**EN61326 (CISPR 11, Group 1, Class B)** Electronic Equipment for Measurement, Control,  
and Laboratory Use EMC Requirements

**EN55022/CISPR 16:1992** Radiated Emissions,  
30 – 230 MHz, 30dBmV/m @ 10m  
230-1000MHz, 37dBmV/m @ 10m

**EN55022/CISPR 16:1992** Conducted Emissions,  
150kHz - 0.5MHz 66-56dB(mV) QP, 56-46dB(mV) AV  
0.5MHz – 5MHz 60dB(mV) QP, 50dB(mV) AV  
5MHz – 30MHz 56dB(mV) QP, 46dB(mV) AV

**EN61000-3-2:1995** Harmonized Emissions

**EN61000-3-3:1995** Flicker Emissions

**EN61000-4-2:1995** Electrostatic Discharge 4kV contact and 8kV  
Air Discharge Performance Criteria B

**EN61000-4-3:1996** Electromagnetic Field Immunity, 3V, 80%  
AM Modulated at 1kHz, Performance Criteria A

**EN61000-4-5:1995** Surges on AC Power Mains, 0.5kV Differential,  
1kV Common Mode, Performance Criteria B

**EN61000-4-6:1996** Conducted RF Current Injection on AC  
Power Mains, 3Vrms, Performance Criteria A

**EN61000-4-11:1994** Voltage Dips and Interruptions on AC Power  
Mains, 0.5 Cycle Each Polarity, 100%

**EN61010-1:1993** Safety Requirements for Electrical Equipment  
for Measurement, Control, and Laboratory Use

These conclusions are based on test report:

**EN61326: 1998 TEST Report for Setra Systems on the Super II Scale with Backlighting  
Model(s)409**

and

**EN61326 (CISPR 11, Group 1, Class B) Emissions Testing Performed on the Setra  
Systems Weighing Scale, Model 409, Super II with Backlighting Option**

*Technical Information File is maintained at:*

Setra Systems, Inc.  
159 Swanson Road  
Boxborough, Massachusetts 01719  
U.S.A.  
Tel: (978) 263-1400  
Fax: (978) 635-9551

Year of CE Marking: 2001

Setra Systems does hereby declare that the product specified above conforms to  
the listed directives and standards.

Setra Systems, Inc.  
159 Swanson Road  
Boxborough, MA 01719

### **FCC Warning**

This equipment has been tested and found to comply with the limits for a Class A digital device pursuant to Part 15 of FCC Rules. These limits are designed to provide reasonable protection against harmful interference when this equipment is operated in a commercial environment. This equipment generates, uses, and can radiate radio frequency energy and, if not installed and used in accordance with the instruction manual, may cause harmful interference to radio communications. Operation of this equipment in a residential area may cause harmful interference, in which case, the user must correct the interference.

### **Canadian Department of Communications**

This digital apparatus does not exceed the Class A limits for radio noise emissions from a digital apparatus set out in the Radio Interference Regulations of the Canadian Department of Communications.

Le présent appareil numérique n'émet pas de bruits radioélectriques dépassant les limites applicables aux appareils numériques de la classe A prescrites dans le règlement sur le brouillage Radioélectrique édicté par le Ministre des Communications du Canada.



INCMANB  
 INER, 14 17  
 epoint99  
 Eucperforma5  
 exponential 12  
  
**F**  
 FAVE  
 FactoryDefau162  
 factorysetting5  
 FCV aring19 10  
 fieldidentifiers5  
 fields  
     E2  
     nonvdtails2  
     toprint15  
     vdtails2  
 FieldPrint15  
 FormatCode5  
 formatcode5  
  
**G**  
 Gbasy42  
 GRAS  
 GRAS  
 GraphID45  
 GREENB  
 Geofg/escg83  
 GREENG 8, 17, 19  
 GoshV eij142  
 GROSSNET tgg 12  
  
**H**  
 handshaking 11  
 handvshandshaking3  
 HGB  
 HISEFOND2  
 HISEW  
 HISIS 16  
  
**I**  
 I47, 112, 142  
 ID112  
 ID112  
 ID312  
 ID112  
 ID112  
 Idetect2  
 Idetb6 42  
 Idish112  
 IDAVE, 16, 37, 42  
 IDAVEEP  
 IDAVEEAR  
 ID112  
 Idstart 12  
 Idregister 13  
 152

ID112  
 ID112  
 ID112  
 immedalepoint 12  
 InrCUI pot83  
 INMANP  
 INQ 71  
 INUCB  
 integrationfilter1 12  
 IntraDatabase5  
 IntraPrintModel 15  
  
**J**  
 jumpcode 12  
  
**K**  
 Keyrad 19  
 keypadrty  
     scrip 19  
 Kiting142  
  
**L**  
 LABEL B  
 label1  
     design19121  
 LabelPrintj 19  
 LANSCAN  
 LARIVIB  
 LESL 10  
 LEFARY 62  
 LEFARY Cabain62  
 LOCAL 10, 12  
 LQA 97  
 LCT 42  
 LQB  
 lowbattery131  
 LOWSPNT 1 12  
  
**M**  
 MAVE  
 Mac43  
 Macrooperator45  
 MAREUP 7  
 MAREURS  
 Macs  
     pumping  
 macs  
     customing5  
     programming6  
     pumping5  
     pumps7  
 MAREUP 5  
 memory 19  
 Mem43  
 MIT AR VDMH Y25  
 modB14

Multipbasecomativity45  
 MultiScatSystem5  
  
**N**  
 NAME, 30 42  
 NetW eij143  
 networkbase5  
 NET 47  
 NEM7  
 NONINERTY 144  
 NONIDA 12  
  
**O**  
 ONDE  
 Operatingtemperature46  
 OR 42  
 ORR  
 output19, 121  
 OZ  
  
**P**  
 PAVEO 132, 146  
 PASUPPER 103, 12  
 PAIB  
 Path41, 143  
 PAR TCB  
 PasswordProtect105  
 P21  
 PortableOperator131  
 PER TR B  
 PER SUP 6  
 PER SUP 2  
 Powerrequirements46  
 Reair143  
 FRN6, 11, 12, 17, 47, 112, 119  
 FRSEUP  
 FRNT format  
     programming2  
 FRNT ROMA 10  
 PrintFormat 1  
 PrintInterval 1  
 FRNT NR VL7  
 FRNT NR VL12  
 FRNEUR 10, 11  
 FRNKEY 12  
 printer  
     serial 19  
     thermabarcode 19  
 printers  
     CS225  
     Etr5  
     SipCode5  
 Printing, 145  
 printing, 11  
     CS225A 20 1  
 Etr01 1





